



US 20080006198A1

(19) **United States**

(12) **Patent Application Publication**
Angelini

(10) **Pub. No.: US 2008/0006198 A1**

(43) **Pub. Date: Jan. 10, 2008**

(54) **BOAT FOLDABLE INTO A COMPACT
SELF-CONTAINED SHAPE**

Publication Classification

(76) Inventor: **Joseph Angelini, Knoxville, TN
(US)**

(51) **Int. Cl.**
B63B 7/02 (2006.01)
B63B 17/02 (2006.01)
B63H 5/02 (2006.01)
(52) **U.S. Cl.** **114/354; 114/361; 440/90**
(57) **ABSTRACT**

Correspondence Address:
KNOX PATENTS
P.O. BOX 30034
KNOXVILLE, TN 37930-0034

An apparatus with two configurations: a deployed configuration forming a watercraft that floats in water and a folded configuration that allows for transport of the apparatus. The apparatus includes multiple modules. One module is a planar sheet of corrugated material with a plurality of joints that allow the sheet to assume the shape of a hull when in the deployed configuration and to assume a box-shape when in the folded configuration. Another module is a paddle assembly that is releasably connected to a pair of sidewalls when the sheet is in the deployed configuration. The paddle assembly is foldable such that it fits within the box-shape when the sheet is in the folded configuration. The planar sheet is foldable around a plurality of joints or hinges that are configured to fold two ways, thereby allowing the sheet to assume the two configurations.

(21) Appl. No.: **11/767,048**

(22) Filed: **Jun. 22, 2007**

Related U.S. Application Data

(60) Provisional application No. 60/805,739, filed on Jun. 24, 2006.

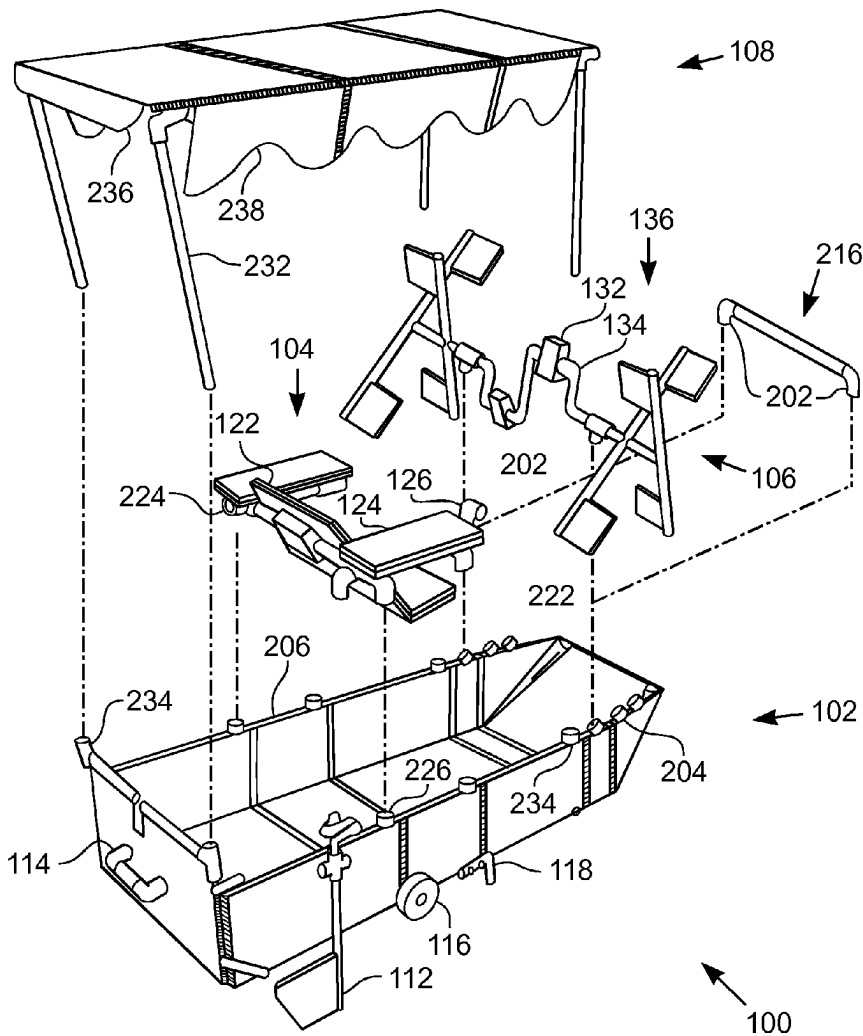

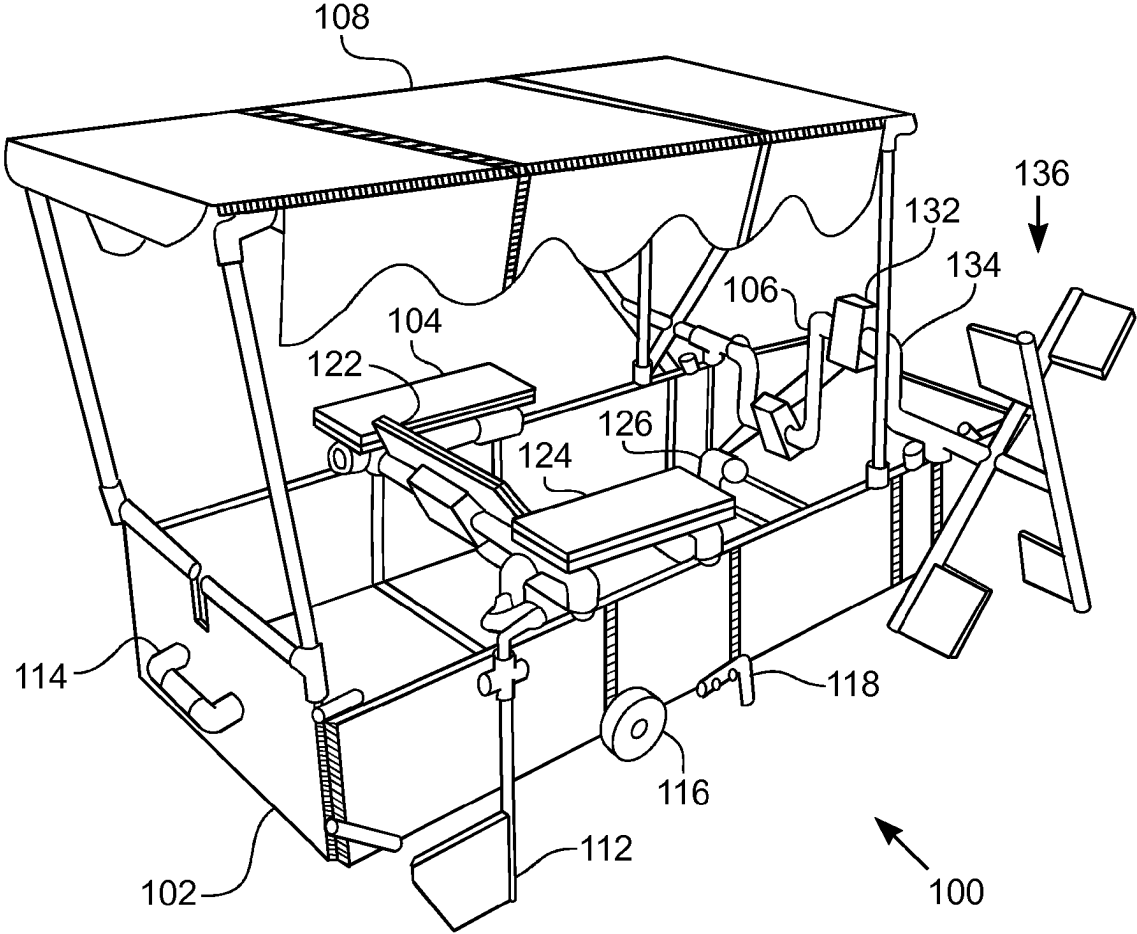

Fig. 1

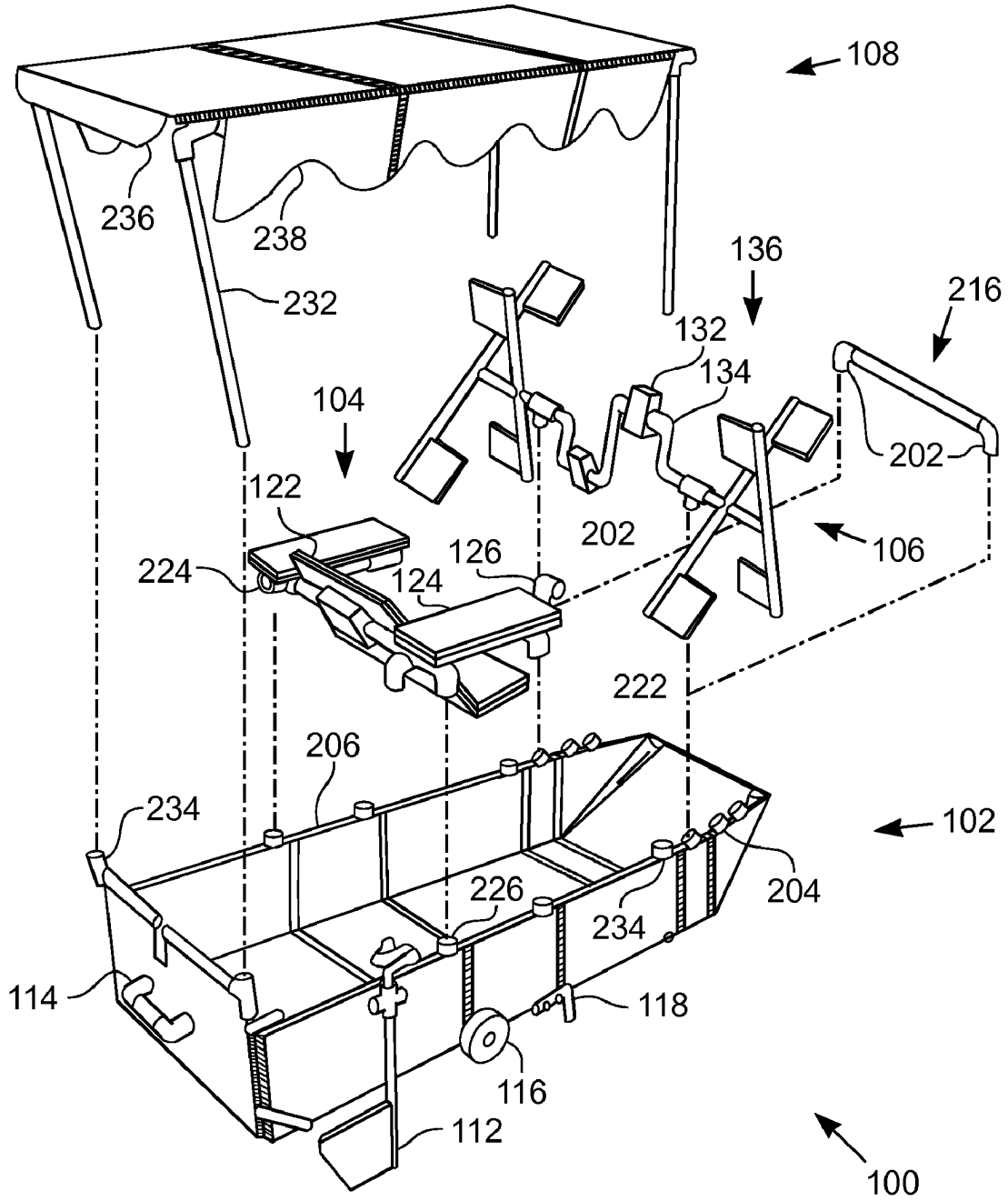

Fig. 2

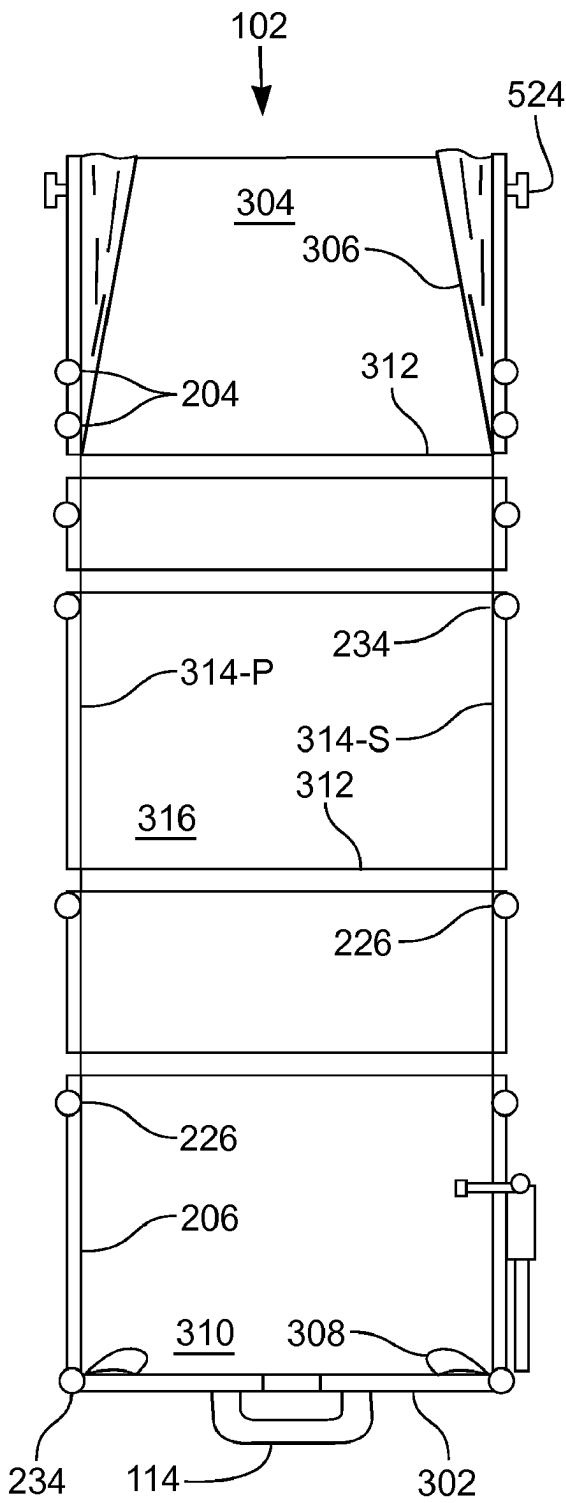

Fig. 3

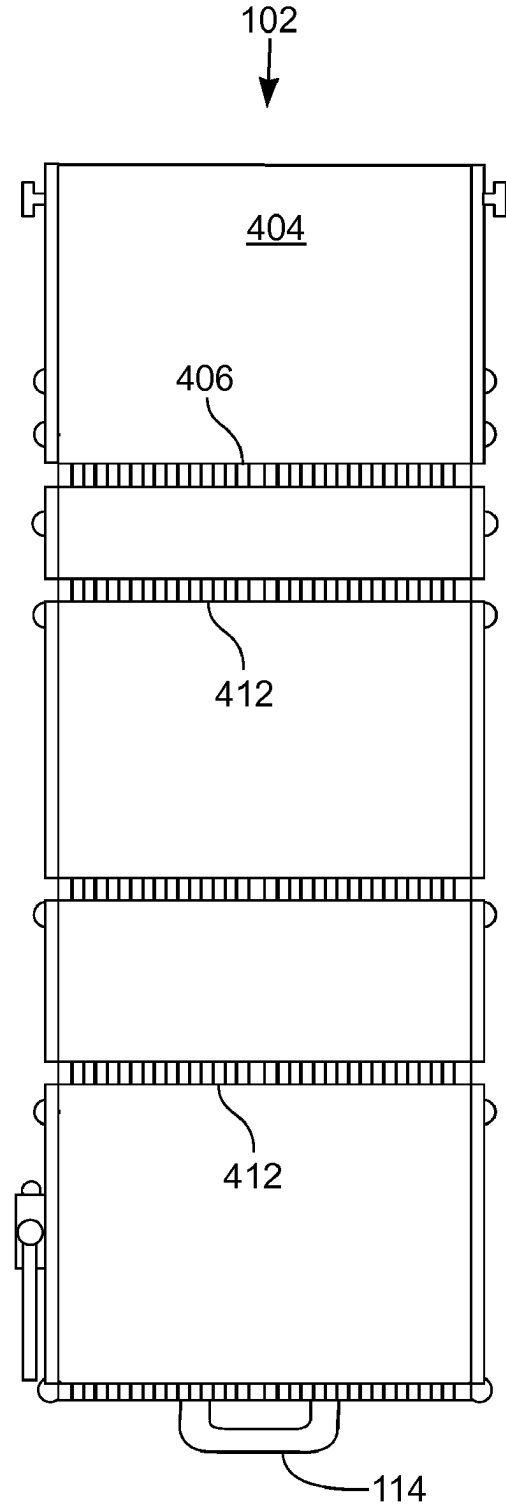

Fig. 4

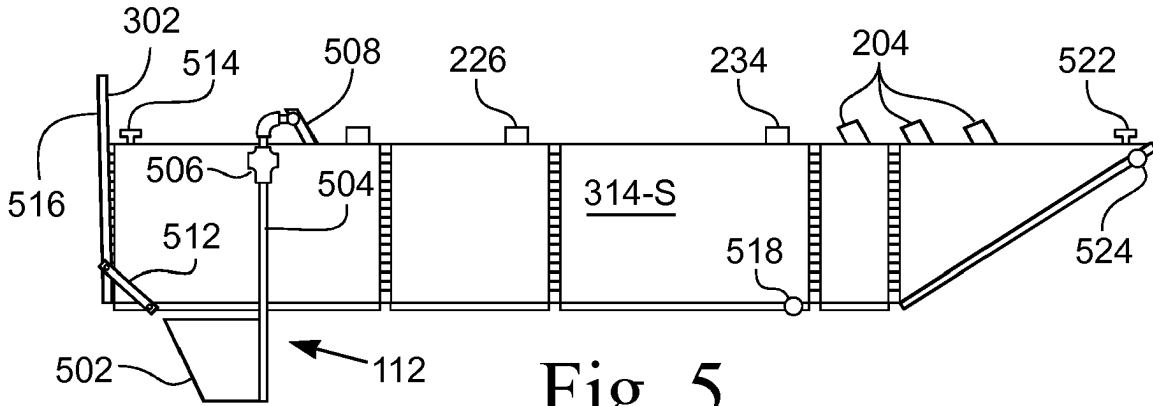

Fig. 5

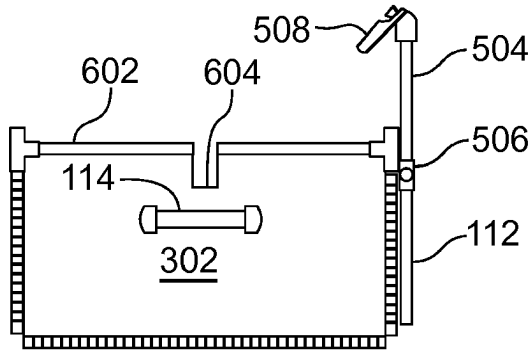

Fig. 6

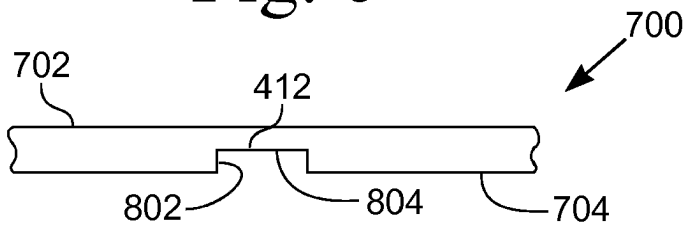

Fig. 8

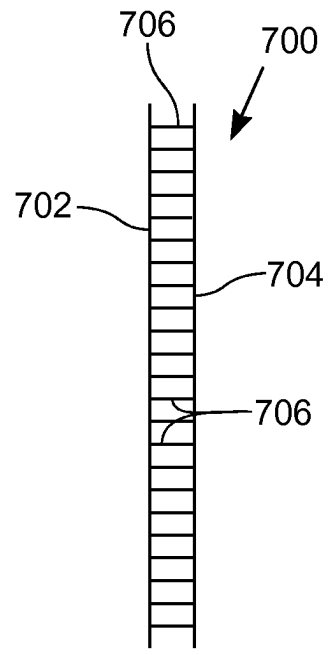

Fig. 7

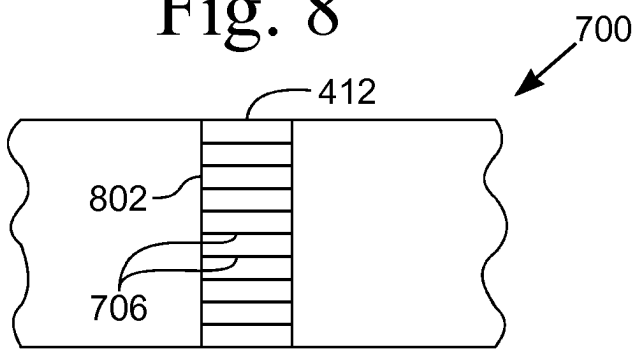

Fig. 9

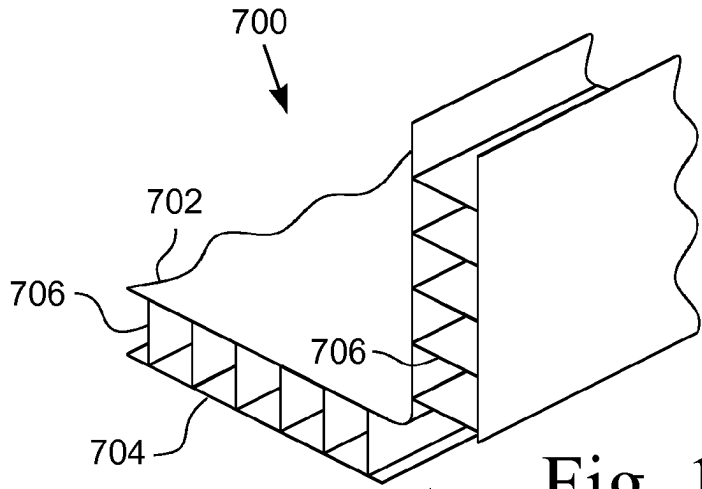

Fig. 10

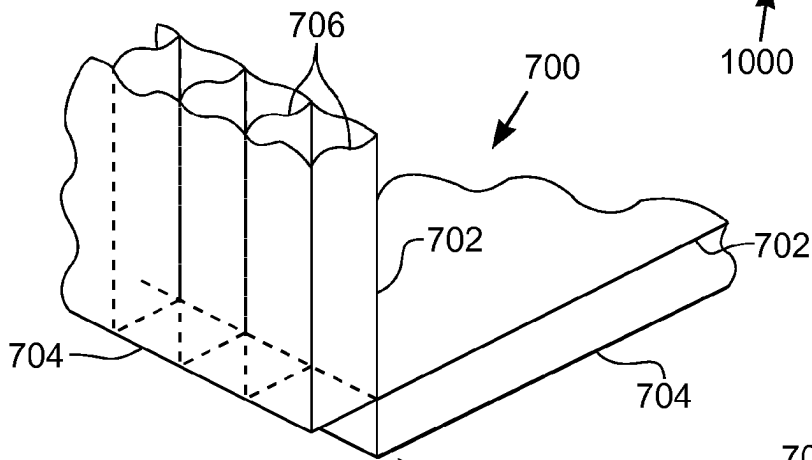

Fig. 11

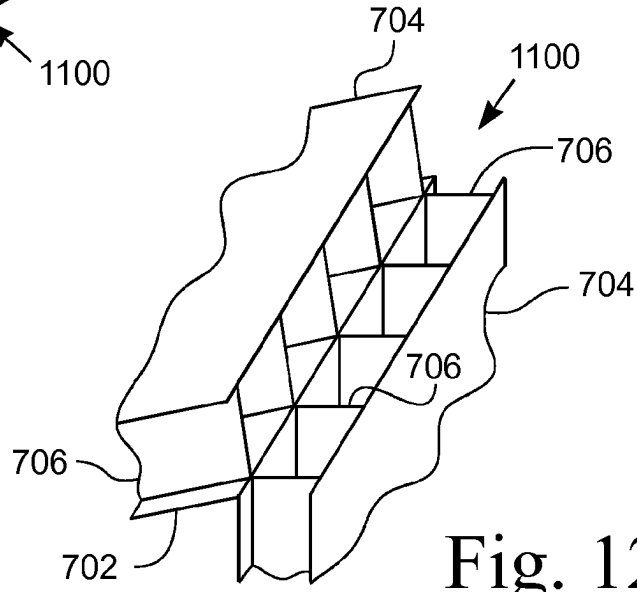

Fig. 12

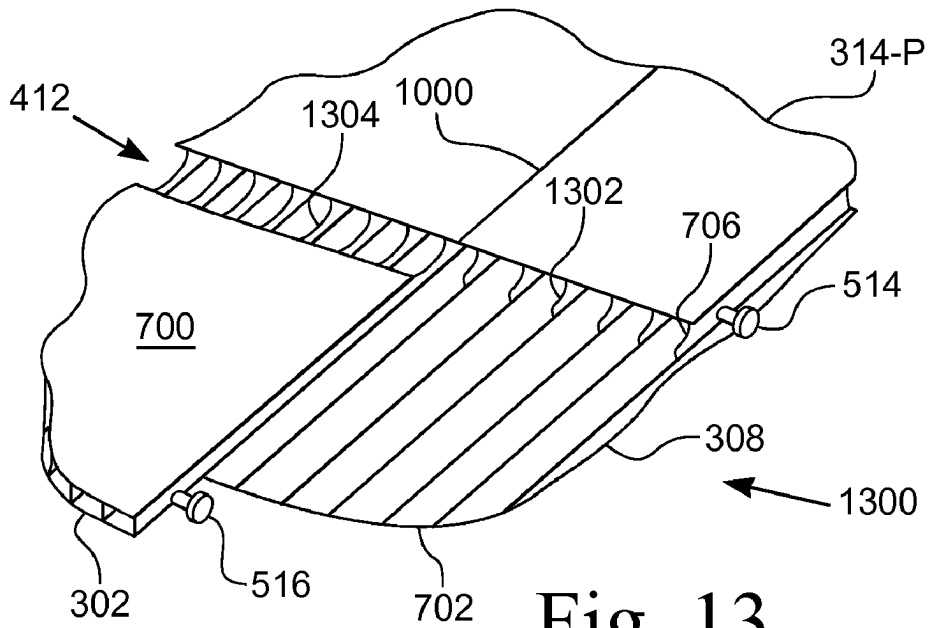

Fig. 13

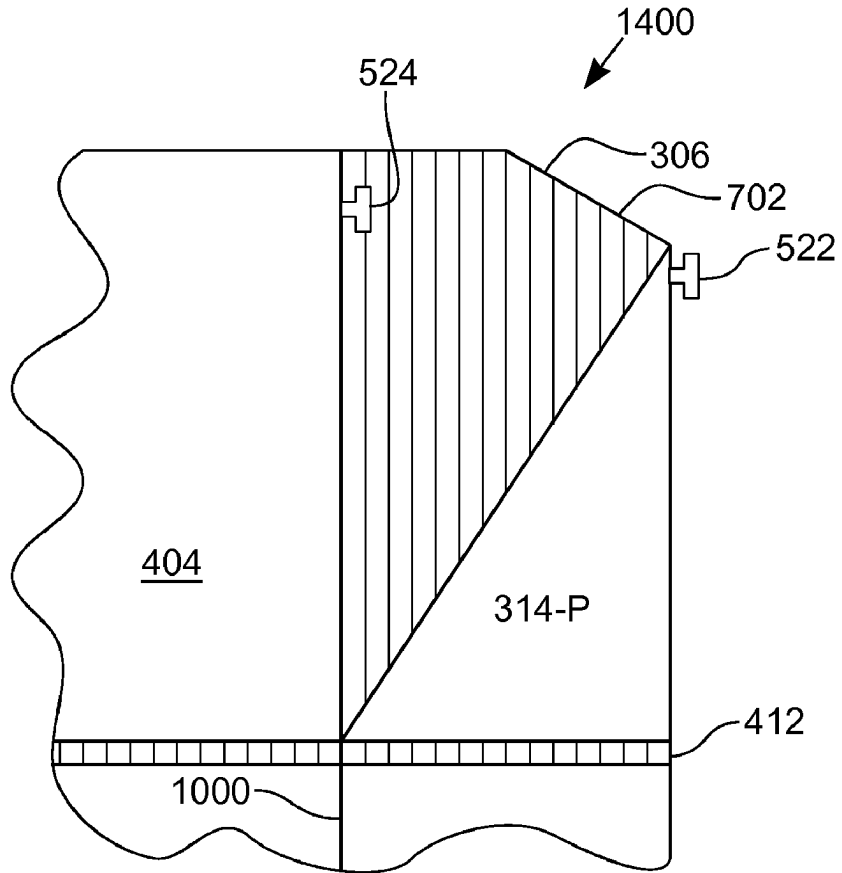

Fig. 14

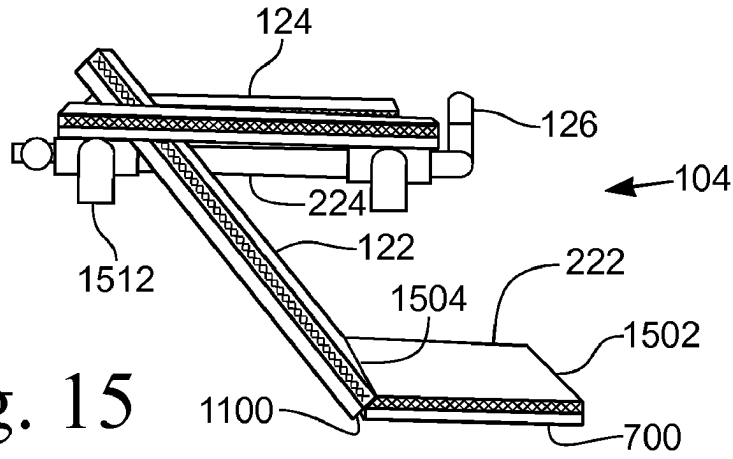

Fig. 15

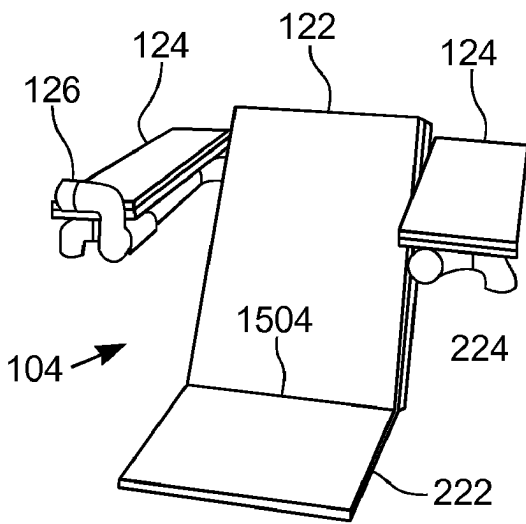

Fig. 16

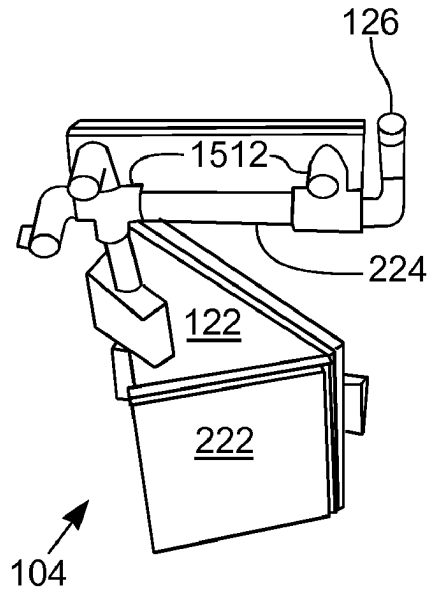

Fig. 17

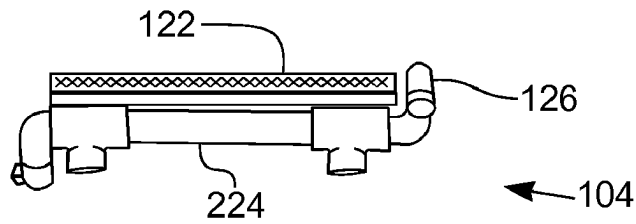

Fig. 18

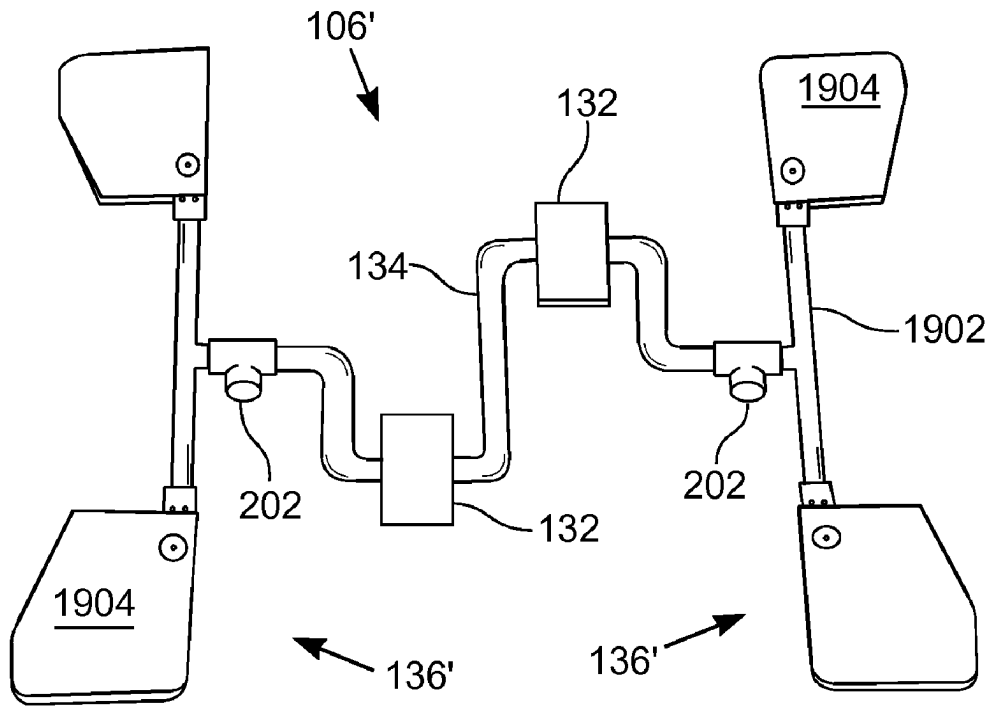

Fig. 19

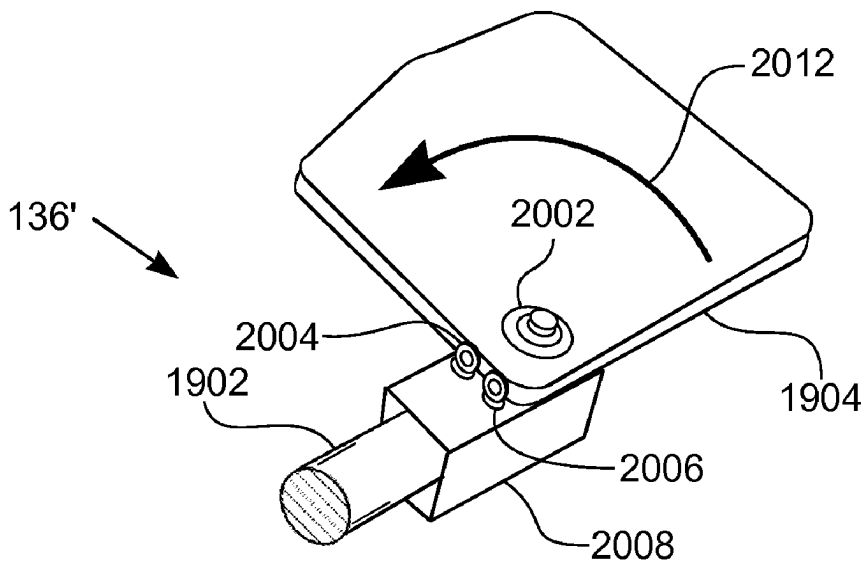

Fig. 20

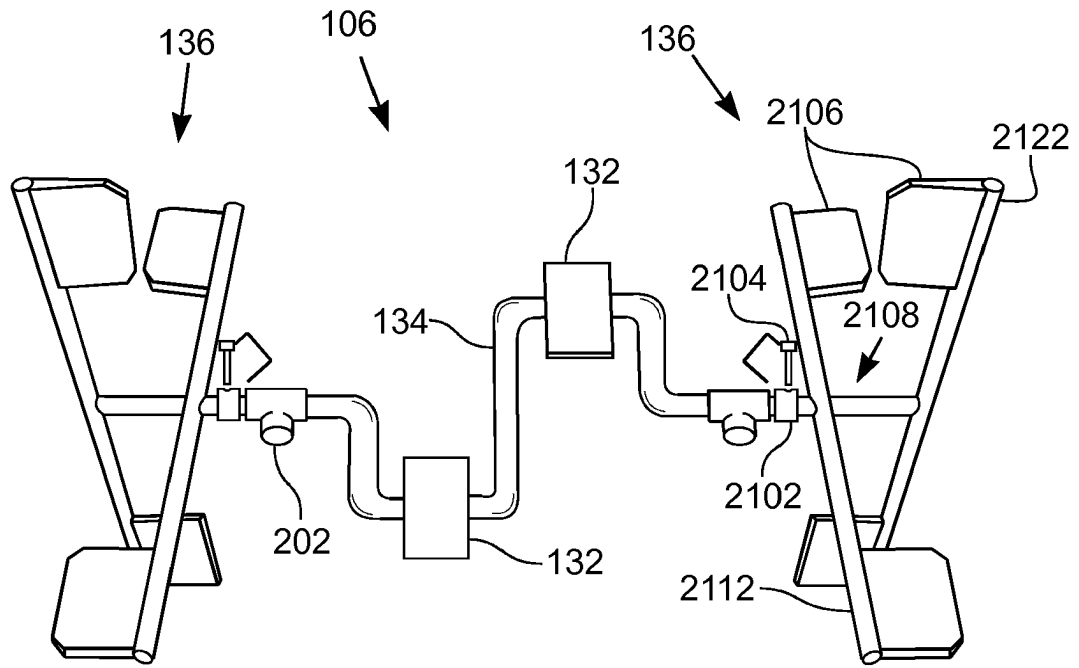

Fig. 21

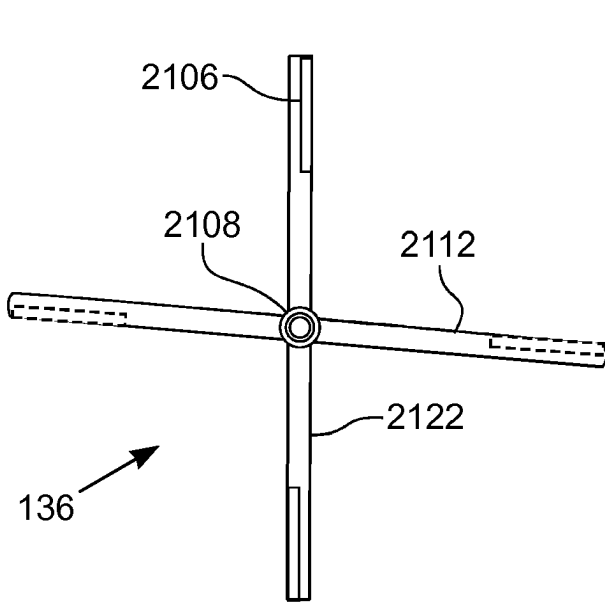

Fig. 22

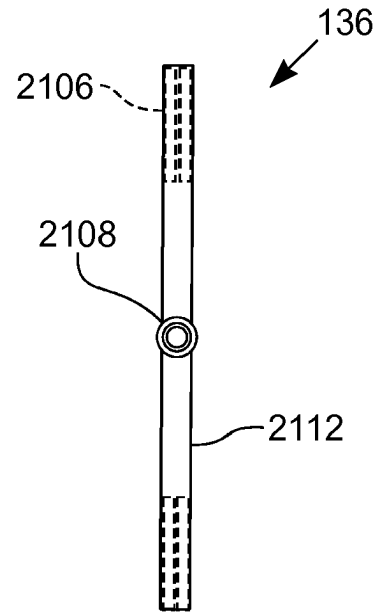

Fig. 23

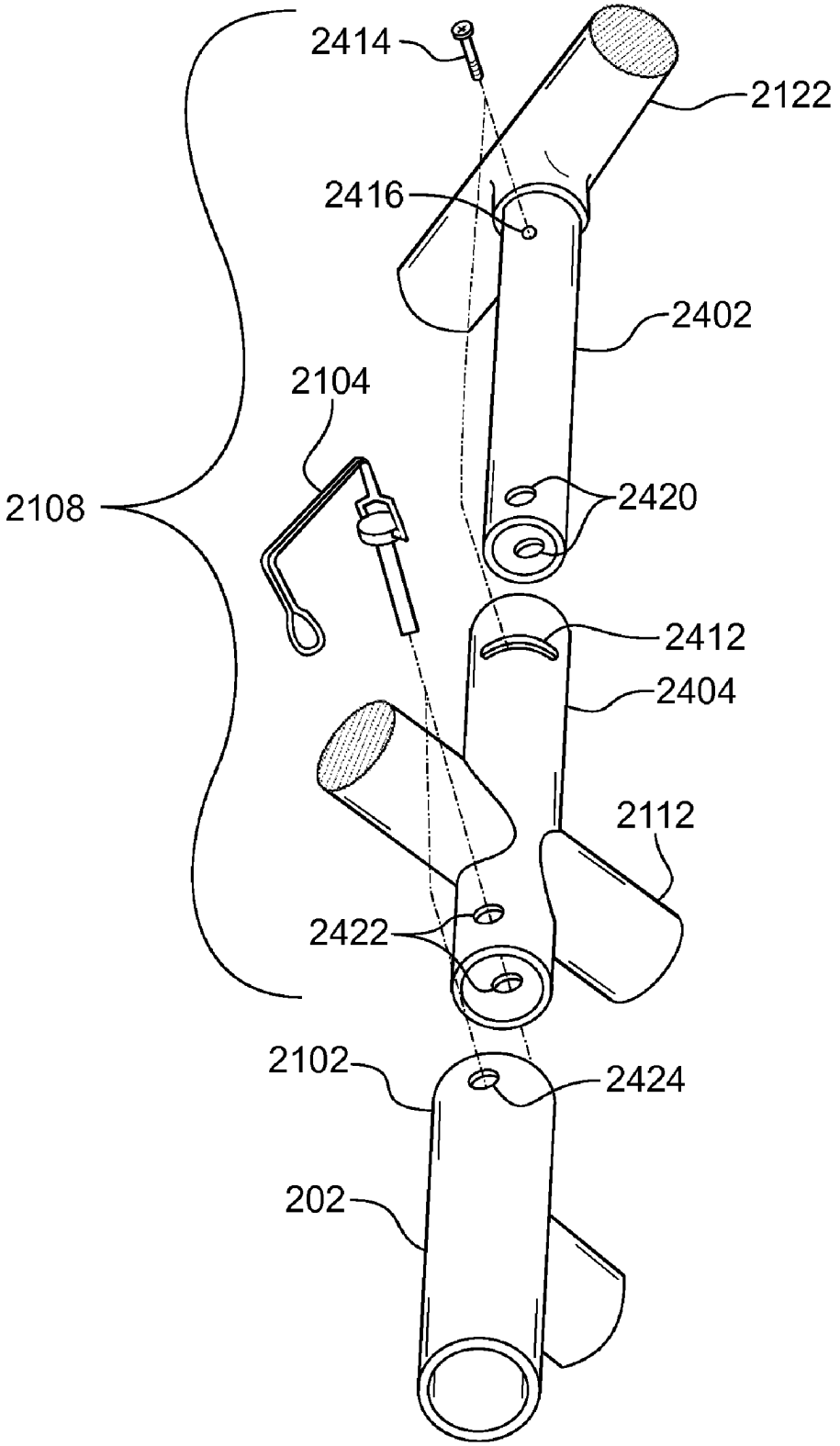

Fig. 24

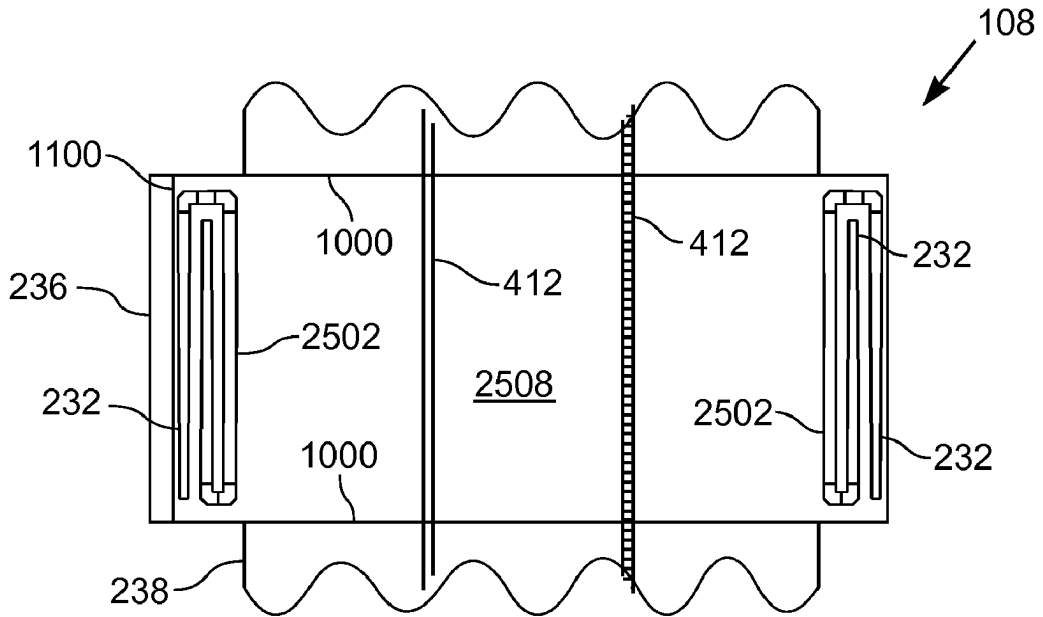

Fig. 25

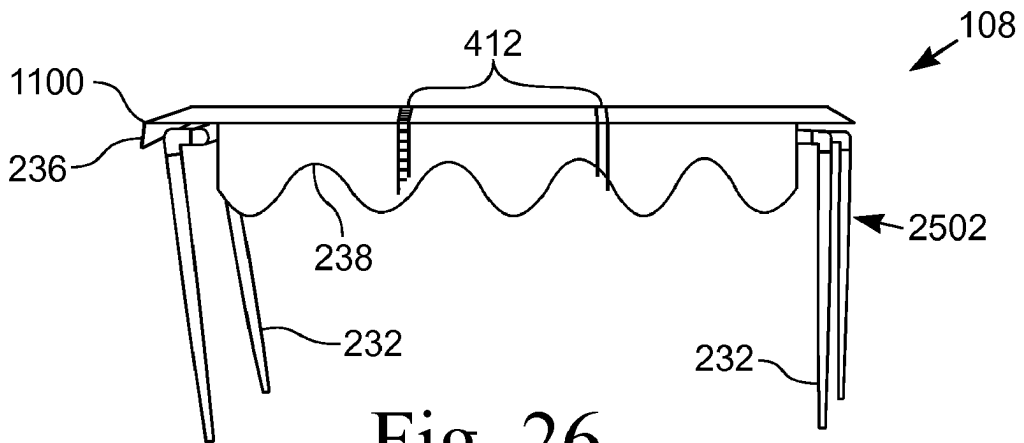

Fig. 26

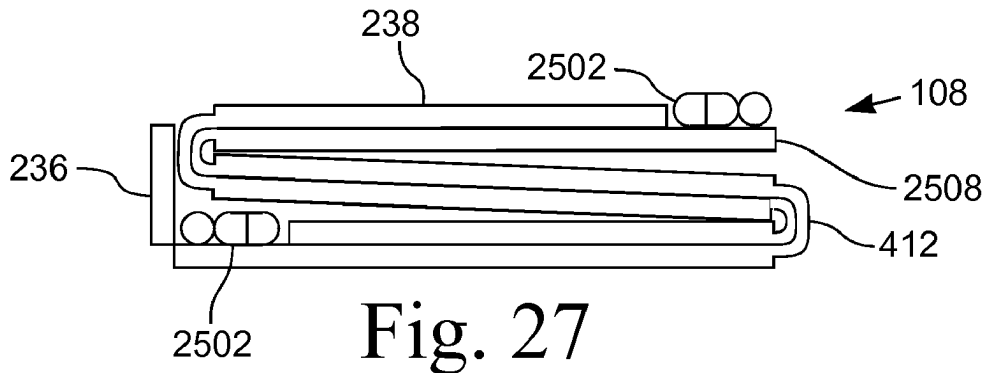

Fig. 27

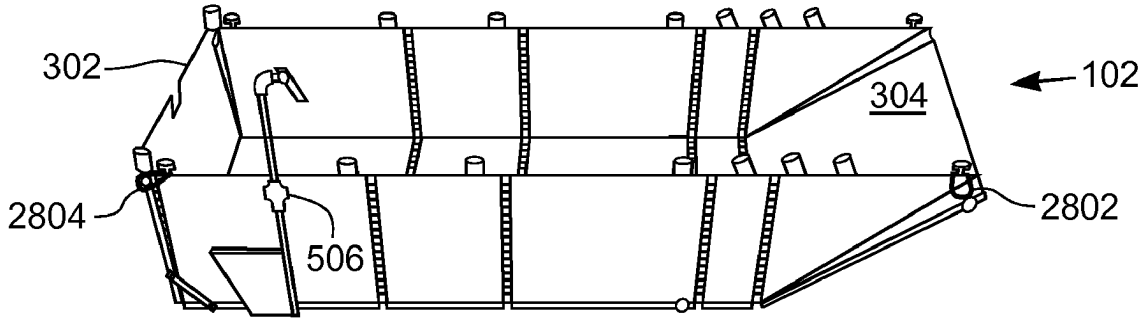

Fig. 28

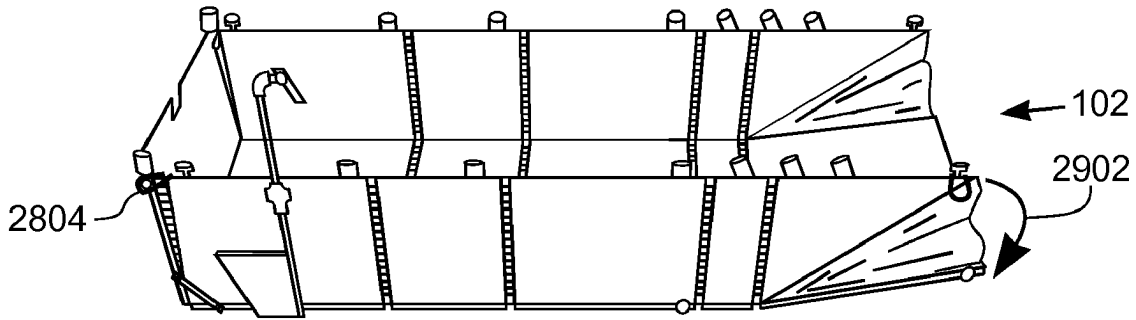

Fig. 29

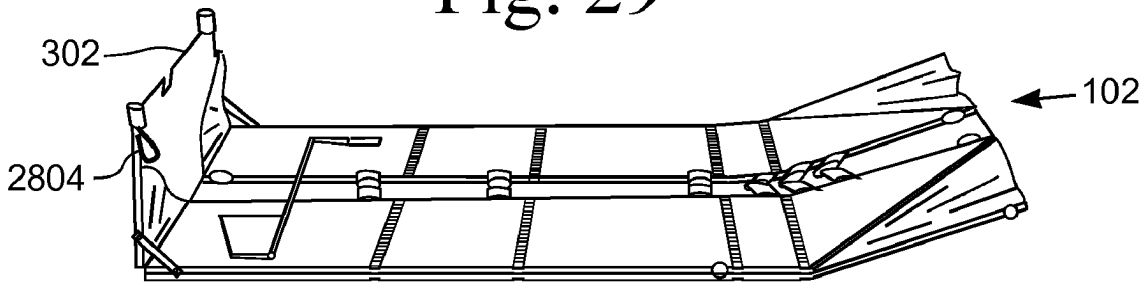

Fig. 30

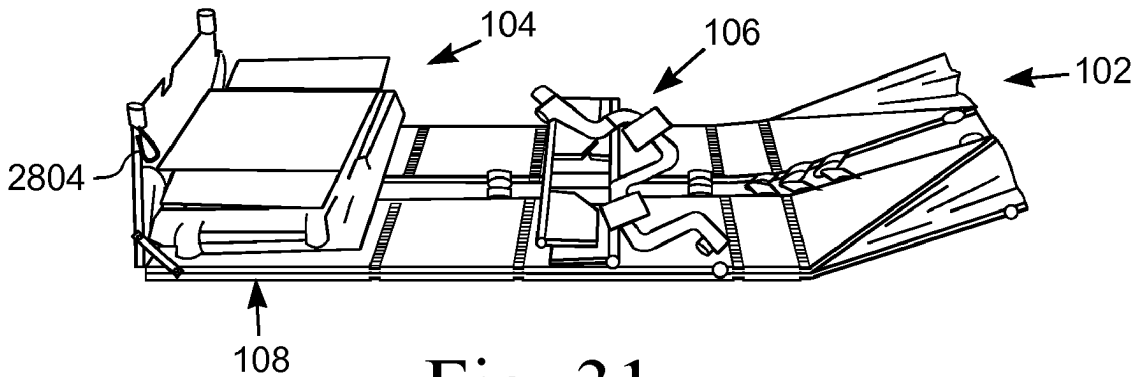

Fig. 31

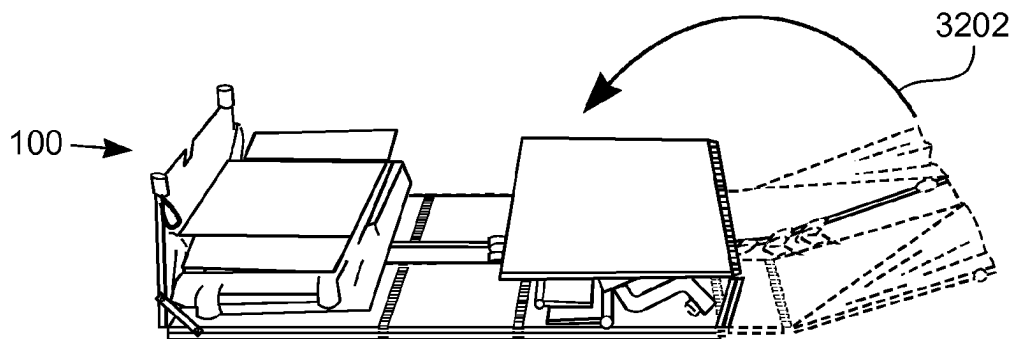

Fig. 32

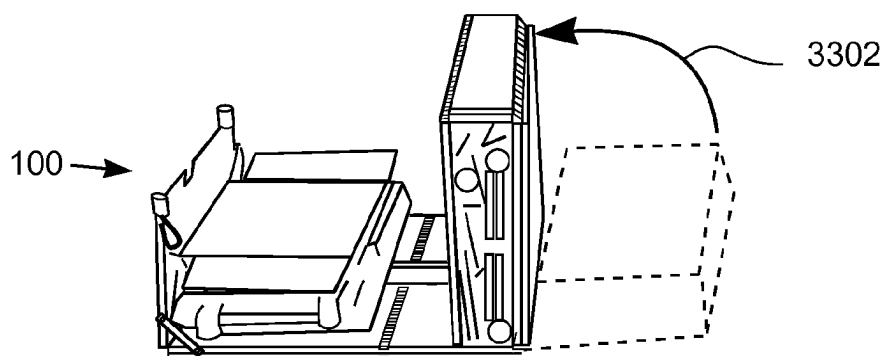

Fig. 33

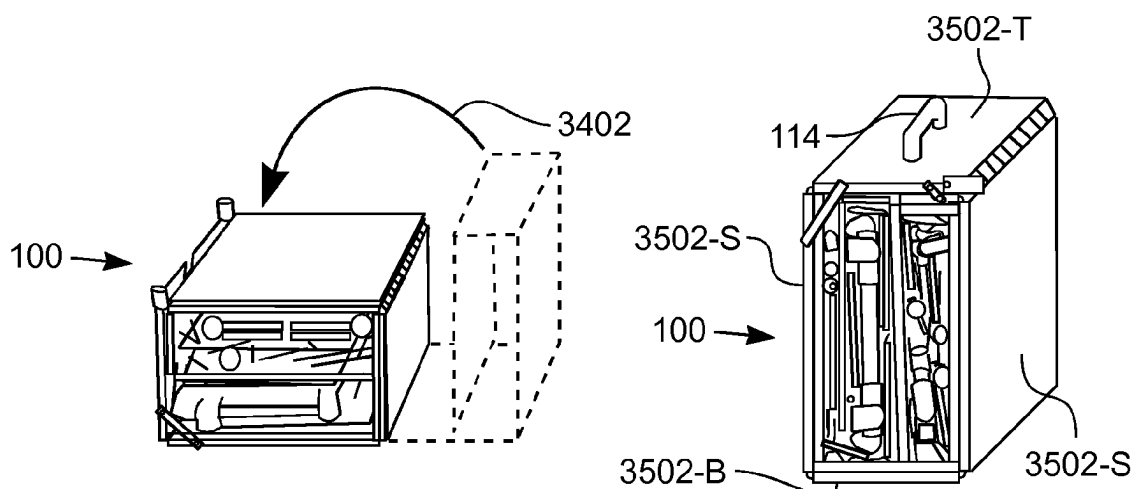

Fig. 34

Fig. 35

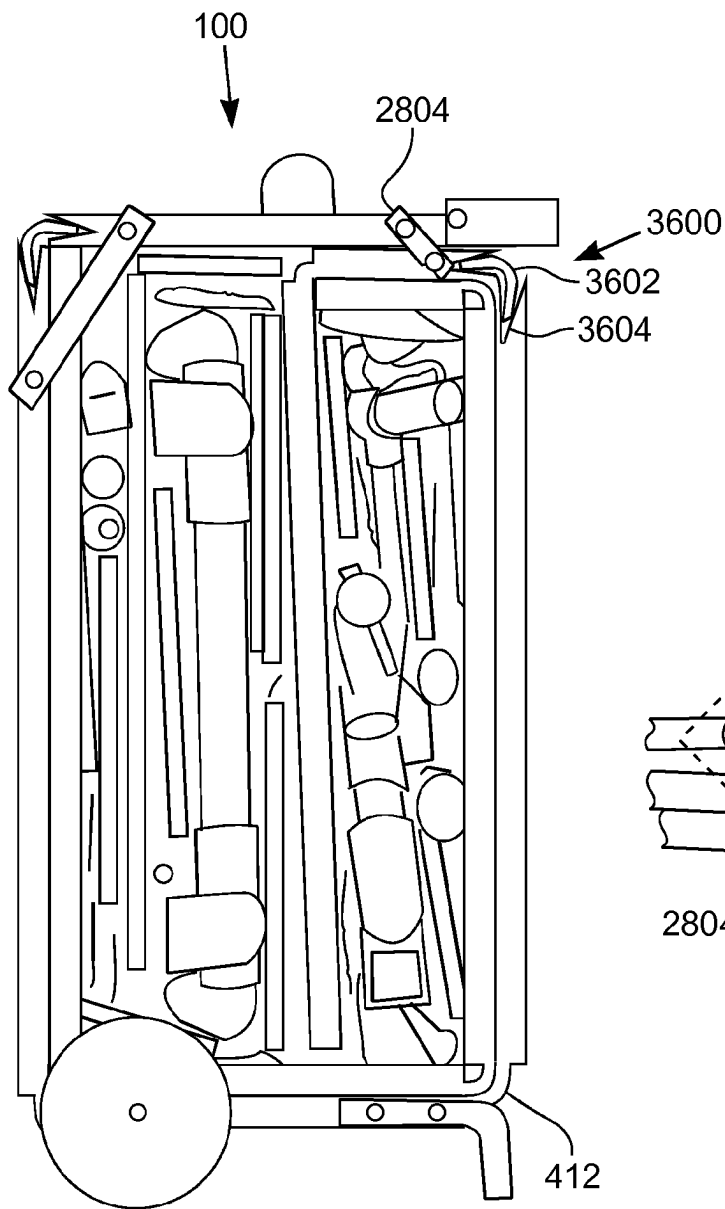

Fig. 36

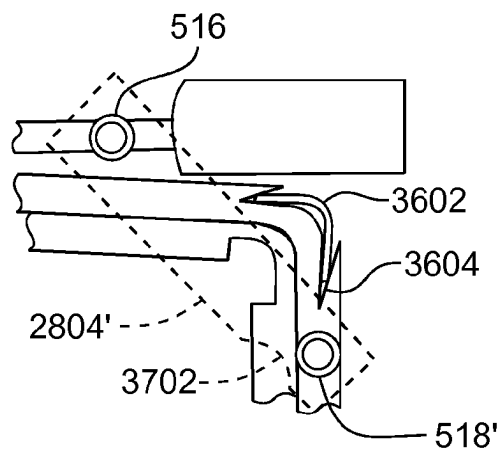

Fig. 37

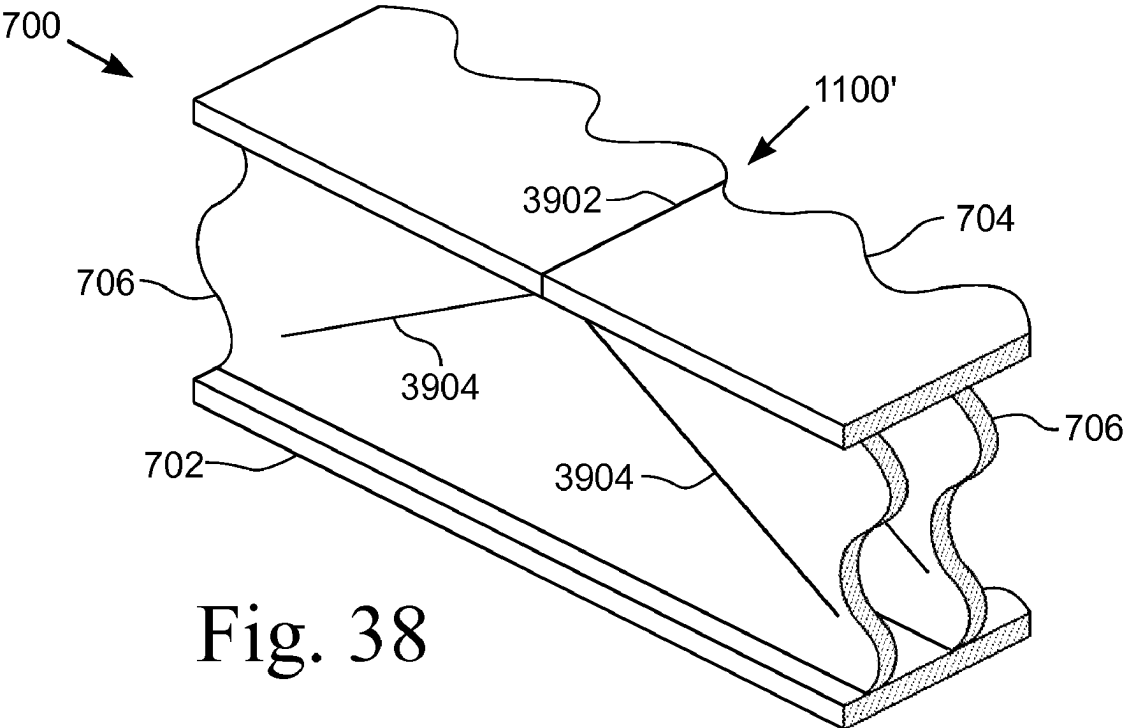

Fig. 38

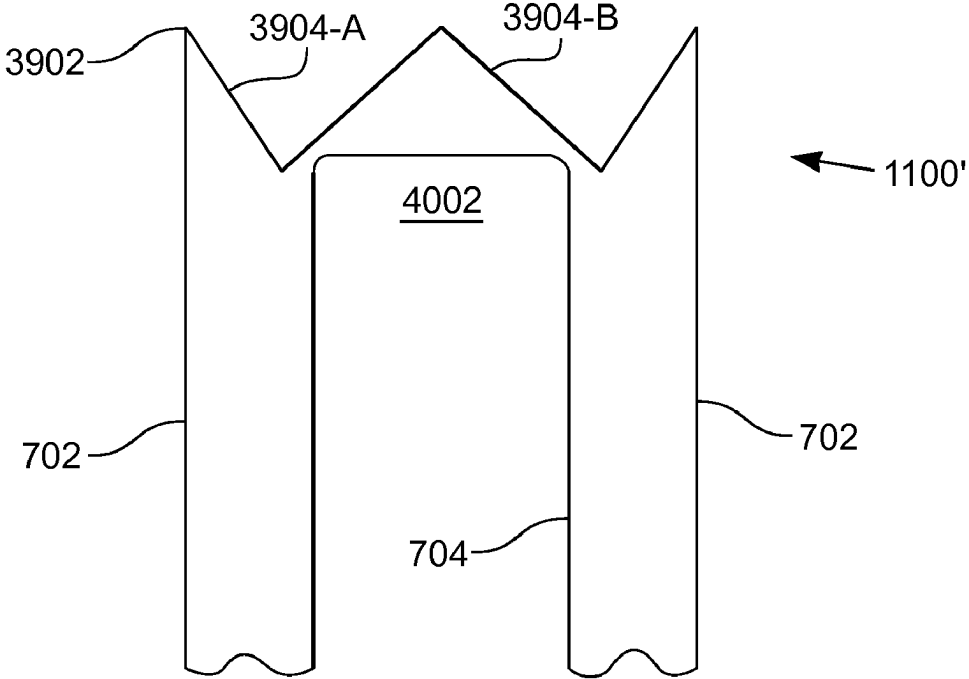

Fig. 39

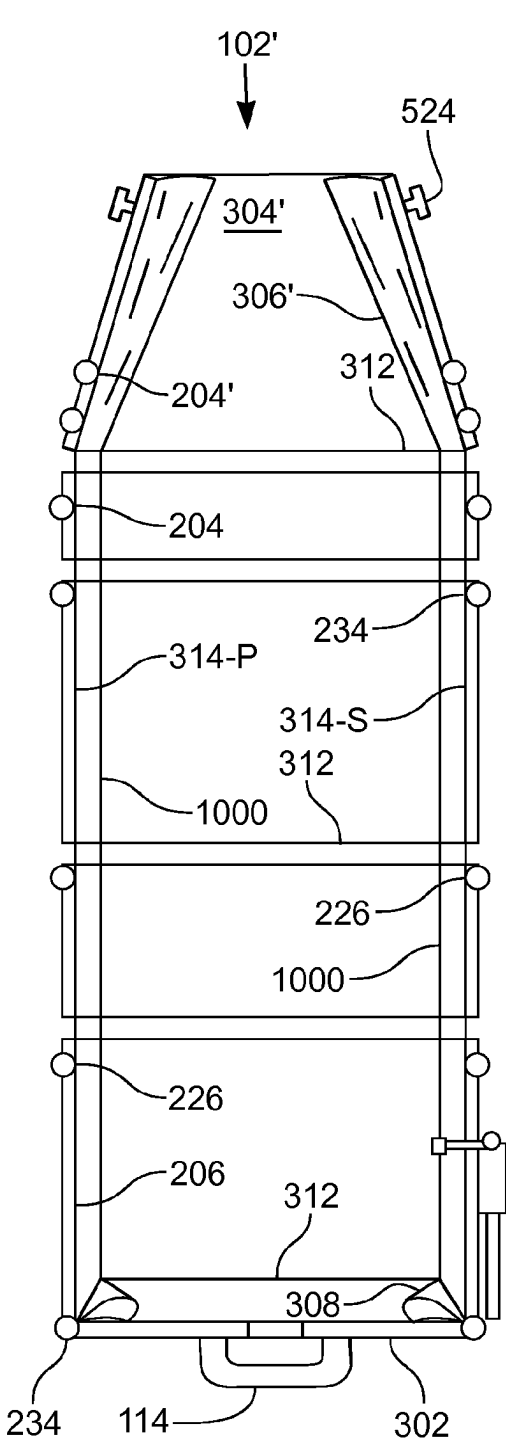

Fig. 40

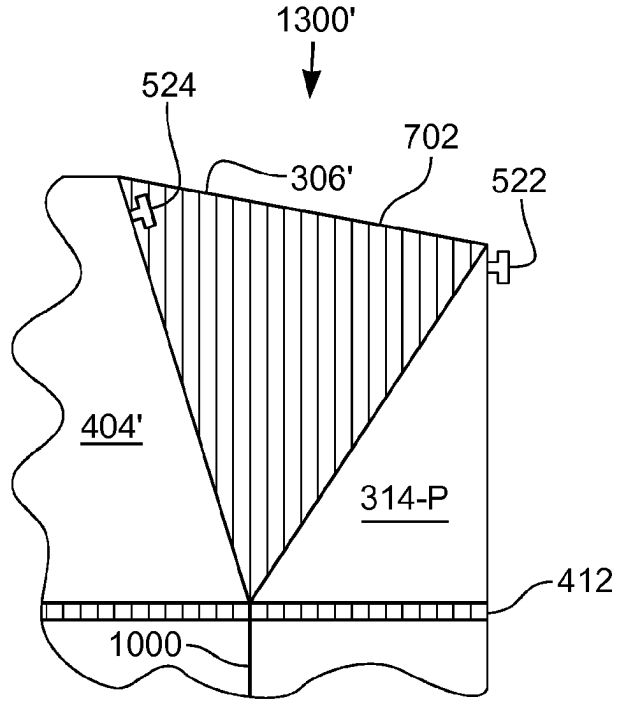

Fig. 41

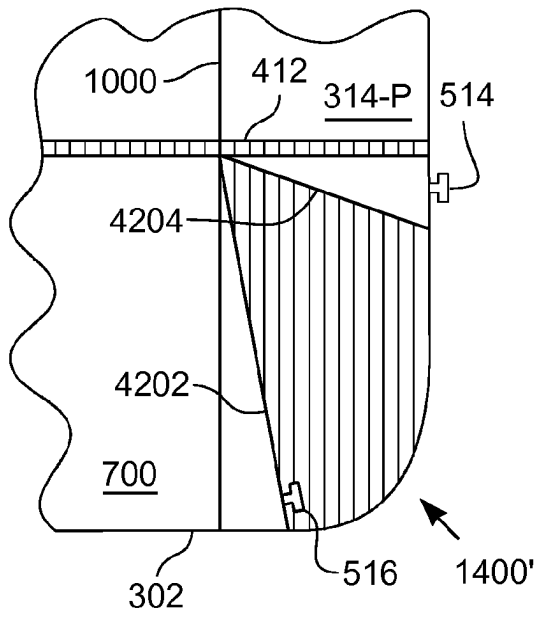

Fig. 42

**BOAT FOLDABLE INTO A COMPACT
SELF-CONTAINED SHAPE**

CROSS-REFERENCE TO RELATED
APPLICATIONS

[0001] This application claims the benefit of U.S. Provisional Application Ser. No. 60/805,739, filed Jun. 24, 2006.

STATEMENT REGARDING FEDERALLY
SPONSORED RESEARCH OR DEVELOPMENT

[0002] Not Applicable

BACKGROUND OF THE INVENTION

[0003] 1. Field of Invention

[0004] This invention pertains to a watercraft in which the hull folds into a suitcase shape. More particularly, this invention pertains to a watercraft in which the hull is formed of a planar sheet that is divided into sections that are joined at integral hinges. The planar sheet is a corrugated material and the hinges are cut or formed into the material. In various configurations, the watercraft includes a canopy, a paddle drive system, a folding built-in seat with integral rudder control, and various hull shapes.

[0005] 2. Description of the Related Art

[0006] Boats, or more generally, watercraft or water vessels, have been in use throughout the history of mankind. Traditionally, boats are big and bulky, typically sized to hold one or more persons. By their nature, boats are rigid, or sufficiently so, to maintain their shape when in the water carrying persons and/or cargo. With the advent of more leisure time, recreational use of boats has increased. To facilitate recreational use, there is a desire to have boats that are easily transportable.

[0007] Various attempts have been made to have boats that are useable in the water and collapsible or foldable for easy transport to the water. The following patents describe some of these attempts: formed from a single sheet. The sheet includes multiple members hinged together such that the members fold into a boat. In the example given in the patent, the members are sandwiched between inner and outer sheets 29, 30. The gap between the members acts as a hinge.

[0008] U.S. Pat. No. 3,771,180, titled "Collapsible portable boat and its method of assembly," discloses a light weight, high buoyancy boat made of corrugated thermoplastic synthetic resin sheets 10, 20, 30. Lines or creases are pressed onto the sheets for folding. In addition to the sheets 10, 20, 30, reinforcing materials 41 are used. The boat includes a vessel portion or a main body. Attached to the main body is a float portion.

[0009] U.S. Pat. No. 4,225,551, titled "Boat hulls," discloses a process for forming a thermoplastic sheet material into a boat hull. The process forms fold lines in a sheet 10. The fold lines have memory and cause the sheet 10 to assume a folded shape. The sheet 10 is readily rolled into a compact package for transportation. When it is unrolled it again tends to assume its folded shape from the memory built into the fold lines.

[0010] U.S. Pat. No. 4,697,540, titled "Collapsible fold-away dinghy," discloses a synthetic single skin 12 having panels joined by flexible watertight webs. The dinghy 10 can be folded into a small package that fits in a car trunk.

[0011] U.S. Pat. No. 4,706,597, titled "Seamless foldable boat," discloses a boat hull formed from a one piece mold.

The hull is a plastic or elastomeric material with foam core construction. The hull bottom includes intrinsically hinged bottom areas 23 between foamed core members. The sides of the hull includes foam cored sides 26 connected to side membranes 25. To provide rigidity, various other members 28, 29, 30 are attached to the one piece hull.

[0012] U.S. Pat. No. 5,203,276, titled "Suitcase boat," discloses a pontoon boat 10 having four sections 16, 18 connected by hinges 22. The boat 10 folds into a suitcase-type configuration with the pontoons, or floats, 24 fitting inside the folded boat sections. U.S. Pat. No. 5,257,584, is a continuation-in-part of the suitcase boat 10 patent application.

[0013] U.S. Pat. No. 5,651,706, titled "Collapsible pontoon pedal boat," discloses a watercraft with a body, two inflatable flotation members, a drive assembly, a steering assembly, and a seat. The body portion folds to form a compact storage case that accommodates all the elements of the watercraft. FIG. 9 illustrates the watercraft in the folded position.

[0014] U.S. Pat. No. 5,957,080, titled "Folding portable boat," discloses a boat 10 with four rigid hull sections 12, 13, 14, 15 that are hingedly connected to fold together or to open into a boat 10. The sections are made of flotation material 61 that is covered with a skin, such as fiberglass, aluminum, thermoplastic, or from a woven structure/resin transfer molding other than fiberglass.

[0015] U.S. Pat. No. 5,975,005, titled "Foldable boat," discloses a boat having an outer hull plate 1 and a waterproofing member 2 that covers the outer hull plate 1. Hull-forming members 10a-h are plank-like members that are connected together by flexible members 3. Tightening the flexible members 3 causes the hull-forming members 10 to form a rigid hull, and loosening the flexible members 3 allows the hull-forming members 10 to fold together accordion-like.

[0016] U.S. Pat. No. 6,615,762, titled "Foldable boat with light weight hull construction system," discloses a boat made with extruded corrugated plastic. The boat hull 47 is formed of sections 8-15 that are flat blank hull sections with fastener holes 49 and hinge score lines 50. The flat blank hull section is folded into the desired shape at the score lines 50, which form living hinges.

[0017] U.S. Pat. No. 6,766,758, titled "Folding boat," discloses a folding boat 10 having a deck 12, safety fences 26, and pontoons 28. The deck 12 includes two main panels connected with a hinge 14 and several drop leaf panels 16 that are hingedly connected to the main panels. Folding the two halves of the deck 12 forms a compact structure.

BRIEF SUMMARY OF THE INVENTION

[0018] According to one embodiment of the present invention, a boat that is constructed such that the boat folds into a self-contained shape is provided. In one embodiment, the boat has four modules: the hull, the seat, the paddle assembly, and the canopy. The modules are separable and collapsible. When deployed, in one embodiment, the hull assumes the general shape of pram, and, in another embodiment, the hull has a more pointed, blunt-nosed, bow. When folded, the boat assumes the shape of box with two open ends that are opposite each other.

[0019] In one embodiment, the hull, when deployed, has the general shape of a pram, that is, it has a flat-bottom, a square stern, and a forward sloping square bow. The hull is

made of a single corrugated plastic sheet, which in one embodiment is an extruded twin-wall plastic sheet of high impact polypropylene copolymer, such as Coroplast. The various joints formed in the copolymer resin allows the hull material to flex and act as a hinge without breaking or cracking.

[0020] The hull is formed from a single corrugated plastic sheet with various connectors attached to the sheet. Three types of fold lines, or joints, are formed in the sheet. The first type of joint is a channel cut joint in which one surface or wall of the sheet is cut away and the length of the exposed flutes are reduced by approximately one-half. The second type of joint is a half-cut joint in which one surface of the sheet is cut such that the opposite surface is the only connection between the two halves of the sheet. The half-cut joint includes a parallel flute half-cut joint in which the one surface is cut parallel with the flutes. Another type of half-cut joint is a cross-flute half-cut joint in which the cut in the one surface of the sheet crosses the flutes, which are also cut down to the opposite surface of the sheet. The third type of joint is a face cut joint in which one surface of the sheet is removed and the flutes between the removed surface and the opposite surface are also removed, leaving only the opposite surface of the sheet.

[0021] The hull has various joints to allow a single sheet to fold to form the hull and to also fold into a box-shape. A face cut joint is made at each of the four corners of the sheet forming the hull. A pair of fore-to-aft parallel flute half-cut joints are made to allow the port and starboard walls of the hull to fold up. A channel cut joint is made in the bottom of the sheet at the bottom of the transom across the width of the sheet. Four additional channel cut joints parallel to the transom channel cut joint are made on the bottom of the sheet. To form the hull, the transom is lifted up to form approximately a right angle with the remainder of the sheet, the port and starboard walls are lifted up to form approximately a right angle with the sheet portion that forms the deck, and the bow section of the deck is lifted up until the extreme forward end is even with the tops of the port and starboard walls. Each of the four top corners of the open hull are then fixed. In one embodiment, a pair of studs protrude from each top corner and the studs are held in fixed relation to each other with a linking member.

[0022] The seat attaches to the hull and allows the operator to maintain a comfortable position in the vessel. The seat includes a frame that attaches to connectors on the hull. The frame, in one embodiment, supports arm rests and the seat back. The seat bottom rests on the bottom inside surface of the hull. The arm rests, seat back, and seat bottom are formed of a foam that provides support and comfort to the seat occupant. In addition, the foam provides flotation when the boat is deployed.

[0023] In one embodiment, a tiller is attached to the seat. The tiller has a hand-grip at one end that allows the tiller to rotate. The opposite end of the tiller from the hand-grip is attached to a rudder that is mounted to the side of the hull. The rudder has a shaft that fits in a sleeve bearing mounted on the hull. The top of the shaft includes a link that connects to the tiller.

[0024] In the folded position, the seat bottom folds flat against the seat back and the two rotate to be substantially parallel with the arm rests. With this configuration, the seat occupies minimal space.

[0025] The paddle assembly provides motive force for the boat. The paddle assembly includes a crankshaft with pedals positioned in front of the seat. The crankshaft rotates within bearing assemblies attached to connectors mounted on the hull. The ends of the crankshaft have paddles that rotate with the crankshaft. In one embodiment, each paddle includes two struts, each with a blade on each end. The outboard strut attaches to an inside shaft and the inboard strut attaches to a hollow shaft. The inside shaft rotates within the hollow shaft. The inside and hollow shafts attach to one end of crankshaft, and they are fixed to the crankshaft by a pin that engages an opening in the inside and hollow shafts and the crankshaft end. The openings are aligned such that, with the pin in place, the struts are substantially perpendicular to each other when viewed from the side. In another embodiment, each paddle includes a single strut with a blade on each end of the strut.

[0026] In one embodiment, in the folded position, the pair of paddles detach from the crankshaft. The struts of each paddle rotate such that they are positioned in one plane.

[0027] In another embodiment, the boat does not use a paddle assembly for motive power and the connectors mounted on the hull to which the crankshaft would attach receive a support strut or cross-member. The support strut adds rigidity to the deployed hull by maintaining the side-walls at a fixed distance and relationship, that is, parallel sidewalls perpendicular to the deck. In one such embodiment, the transom of the hull is configured to receive an outboard motor.

[0028] The canopy, when deployed, attaches to the hull to protect the operator and/or passengers from the elements. The canopy is formed from a single corrugated plastic sheet with two channel cut joints positioned between the fore and aft portion of the canopy. The two joints allow the canopy to fold with each of the outboard panels adjacent opposite sides of the center panel when the canopy is in the folded position. The fore and aft ends of the canopy have a support pole at each corner that attach to a mating connector mounted on the hull. In one embodiment, the pair of support poles at each end are hingedly connected to a crosspiece such that the support poles fold flat adjacent the crosspiece. The canopy includes a pair of side curtains that provide rigidity to the top of the canopy.

[0029] The steps to fold the boat include separating the four modules. The next step is to disconnect the sidewalls from adjacent sidewalls. The sheet forming the hull is then folded such that the port and starboard walls are folded inward and positioned adjacent the deck. One of the modules, other than the hull module, is folded and placed on the partially folded hull sheet next to the bow panel. The bow panel is folded over the module. The other two modules are folded and placed adjacent the first folded module and the portion of the hull sheet enclosing the first module is folded over the other modules. The pair of studs associated with the top of the transom are connected to another pair of studs by connecting links to secure the hull in the folded position with the other modules clamped inside the folded hull. A handle is attached to the outboard end of the transom, which forms the top of the box-shape.

[0030] In one embodiment, the folded boat includes a pair of wheels and a pair of legs opposite the handle. The wheels

are adapted to allow the folded boat to be rolled. The legs are positioned to allow the boat in the folded position to rest on the legs and the wheels.

BRIEF DESCRIPTION OF THE SEVERAL VIEWS OF THE DRAWINGS

[0031] The above-mentioned features of the invention will become more clearly understood from the following detailed description of the invention read together with the drawings in which:

[0032] FIG. 1 is a perspective view of one embodiment of the boat;

[0033] FIG. 2 is an exploded view of one embodiment of the boat;

[0034] FIG. 3 is a top plan view of the hull;

[0035] FIG. 4 is a bottom plan view of the hull;

[0036] FIG. 5 is a side plan view of the hull;

[0037] FIG. 6 is a back view of hull showing the transom;

[0038] FIG. 7 is an end view of a section of the corrugated plastic sheet;

[0039] FIG. 8 is an end view of a channel cut joint;

[0040] FIG. 9 is a front view of the channel cut joint;

[0041] FIG. 10 is a perspective view of a parallel flute half-cut joint;

[0042] FIG. 11 is a perspective view of one embodiment of a cross-flute half-cut joint;

[0043] FIG. 12 is another perspective view of the cross-flute half-cut joint;

[0044] FIG. 13 is a perspective bottom view of a face cut adjacent the transom;

[0045] FIG. 14 is a bottom plan view of a face cut at the bow of the boat;

[0046] FIG. 15 is a perspective view of the seat in the deployed position;

[0047] FIG. 16 is a perspective view of the seat;

[0048] FIG. 17 is a perspective bottom view of a partially folded seat;

[0049] FIG. 18 is a side view of a seat in the folded position;

[0050] FIG. 19 is a view of another embodiment of a paddle assembly;

[0051] FIG. 20 is a partial view of one embodiment of a paddle;

[0052] FIG. 21 is a perspective view of one embodiment of the paddle assembly;

[0053] FIG. 22 is a side view of a paddle in the deployed position;

[0054] FIG. 23 is a side view of a paddle in a folded position;

[0055] FIG. 24 is an exploded view of the paddle folding mechanism;

[0056] FIG. 25 is a bottom view of the canopy in the partially folded position;

[0057] FIG. 26 is a side perspective view of the canopy in the deployed position;

[0058] FIG. 27 is a side view of the canopy in the folded position;

[0059] FIG. 28 is a perspective view of the hull in the deployed position;

[0060] FIG. 29 is a perspective view of the hull with the forward and rear sections released from the deployed position;

[0061] FIG. 30 is a perspective view of the hull in the partially folded position with the side walls folded;

[0062] FIG. 31 is a perspective view of the boat in the partially folded position with the four modules positioned together;

[0063] FIG. 32 is a perspective view of the boat in the partially folded position with the forward end of the hull folded;

[0064] FIG. 33 is a perspective view of the boat in the partially folded position with the midship and forward end of the hull folded;

[0065] FIG. 34 is a perspective view of the boat in the folded position resting on a side of the folded box-shape;

[0066] FIG. 35 is a perspective view of one embodiment of the boat in the fully folded position resting on the bottom;

[0067] FIG. 36 is a side perspective view of another embodiment of the boat in the fully folded position;

[0068] FIG. 37 is a close-up view of a latching connection of the boat in the fully folded position;

[0069] FIG. 38 is a perspective view of another embodiment of a cross-flute half-cut joint;

[0070] FIG. 39 is a side view of the embodiment of a cross-flute half-cut joint shown in FIG. 38;

[0071] FIG. 40 is another embodiment of a top plan view of the hull;

[0072] FIG. 41 is a bottom plan view of another embodiment of a face cut at the bow of the boat; and

[0073] FIG. 42 is a bottom plan view of another embodiment of a face cut adjacent the transom.

DETAILED DESCRIPTION OF THE INVENTION

[0074] An apparatus that operates on water as a vessel and is capable of folding into a compact, portable box-shape is disclosed. Water sports would be enjoyed by many more people if it were possible to easily transport a boat to the water. Many prior art boats and water vessels have rigid hulls that assume only a single shape.

[0075] The present invention is a vessel with modular construction that is very compact, totally self-contained, and lightweight.

[0076] FIG. 1 illustrates a perspective view of one embodiment of a folding boat 100. FIG. 2 illustrates an exploded view of one embodiment of the boat 100. The boat 100 has four modules: a hull 102, a seat 104, a paddle assembly 106, and a canopy 108.

[0077] In the illustrated embodiment, the hull 102 is in the deployed position and has the general shape of a pram with a flat bottom or deck 316, a square stern 310, and a square bow 304. Attached to the stern of the boat 100 is a handle 114 for use when the boat 100 is folded. Also attached to the hull 102 is a rudder assembly 112, a pair of wheels 116, and a pair of legs 118. With the boat 100 in the folded position, the wheels 116 and the legs 118 allow the folded boat 100 to be easily maneuvered by grasping the handle 114 and rolling the folded boat 100. In another embodiment, the wheels 116 and legs 118 are not attached to the hull 102 and the folded boat 100 is maneuvered by picking up and carrying the boat 100 by the handle 114.

[0078] The illustrated seat 104 includes a seat back 122 between a pair of arm rests 124. A tiller 126 is positioned adjacent one of the arm rests 124 and is releaseably and operatively connected to the rudder assembly 112. The seat back 124 and arm rests 124 are supported by a seat frame 224. Attached to the seat back 124 is a seat bottom 222 that

rests on the inside bottom surface of the hull 102 when the seat 104 is in the deployed position.

[0079] The illustrated paddle assembly 106 includes a crankshaft 134 with a pair of foot-operated pedals 132. The crankshaft 134 rotates the paddles 136 positioned on opposite sides of the hull 102. In another embodiment, a hull cross-member 216 illustrated in FIG. 2 replaces the paddle assembly 106. Such an embodiment is suitable for using the boat 100 with other motive means, such as oars, paddles, or an auxiliary motor. The hull cross-member 206 connects to the hull 102 and provides support to the port and starboard walls 314-P, 314-S of the hull 102.

[0080] The illustrated canopy 108 extends from the stern of the boat 100 to near the paddle assembly 106. The canopy 108 covers the occupant of the seat 104. The canopy 108 includes side curtains 238 and a back curtain 236. Extending from the canopy 108 are four support posts 232 that attach to the hull 102. In other embodiments, the canopy 108 has a different shape and configuration and provides coverage of only a portion of the occupant of the seat 104.

[0081] The gunwales 206 of the hull 102 are the topmost edge of the hull 102 and include several connectors 204, 226, 234. The frame 224 of the seat 104 attaches to seat connectors 226 amidships. The paddle assembly 106 includes a connector half 202 that mates with a corresponding connector 204 positioned toward the bow 304. The illustrated embodiment shows a set of three paddle connectors 204 attached to each side of the hull 102. By connecting the paddle assembly 106 to one of the three pairs of connectors 204, the distance between the seat 104 and the pedals 132 on the crankshaft 134 is adjustable to fit the size of the occupant of the seat 104. In the illustrated embodiment, the three pairs of connectors 204 are angled toward the stern of the hull 102 because of the forward pressure exerted on the crankshaft 134 through the pedals 132.

[0082] The hull cross-member 216 connects to the same connectors 204 when the paddle assembly 106 is not attached to the hull 102. The cross-member 216 bridges the sidewalls 314 to maintain the sidewalls 314 in a substantially fixed position relative to each other. The paddle assembly 106 includes a crankshaft 134 that is a cross-member and serves the same purpose as the hull cross-member 216. The seat 104 also includes members that connect to the gunwales 206 and serves the same purpose as the hull cross-member 216. The support posts 232 of the canopy 108 attach to the canopy connectors 234 at the stern 310 and near the bow 304.

[0083] FIG. 3 illustrates a top plan view of the hull 102. The hull 102 has a deck 316 defined by a bow 304 and a stern 310. The deck 316 and transom 302 are between the port wall 314-P and the starboard wall 314-S of the hull 102. On the opposite end of the hull 102 from the transom 302 is the bow 304, or the forward section of the hull 102. Because the hull 102 is formed of a single sheet of corrugated plastic, stern folds 308 are adjacent the transom 302 and forward folds 306 are in the bow 304 with the hull 102 in the deployed position.

[0084] FIG. 4 illustrates a bottom plan view of the hull 102. Visible on the upper surface of the inside of the hull 102 in FIG. 3 are fold creases 312 that correspond to the edges of the channel cut joints 412 positioned on the bottom of the hull 102. With the hull 102 in the deployed position, the channel cut joints 412 on the bottom of the hull 102 are flat except for the most forward joint 406, which is slightly

hinged, tilting the forward panel section 404 and forming the forward fold 306 at the bow 304.

[0085] FIG. 5 illustrates a side plan view of the hull 102. The rudder assembly 112 includes a rudder blade 502 attached to a rudder shaft 504. The rudder shaft 504 rotates and slides within a rudder bearing 506 that is attached to the starboard wall 314-S of the hull 102. The rudder shaft 504 has an upside-down L-shape with the upper end attached to rudder link 508 that attaches to the tiller 126.

[0086] The transom 302 has a pair of studs 516 and each wall 314 of the hull 102 has a stud 514. With the transom 302 and side walls 314 positioned in the deployed position, each pair of studs 516, 514 are linked together with a connector (not illustrated). Between the side of the transom 302 and the bottom of the side wall 314 is a brace 512 that rigidly supports the lower portion of the transom 302 relative to the rest of the hull 102.

[0087] At the bow 304, the forward end of each side wall 314 has a stud 522 and the forward bottom panel section 404 of the hull 102 has a stud 524. When the forward panel section 404 is tilted up, the two studs 522, 524 are brought near each other and they are linked together with a connector (not illustrated).

[0088] FIG. 6 illustrates a back view of the hull 102 showing the transom 302 and the handle 114 attached to the transom 302. With the hull 102 resting on a surface, the rudder assembly 112 is in an elevated position. The rudder shaft 504 slides within the rudder bearing 506 to prevent the rudder assembly 112 from being damaged when the boat 100 is not in the water. When in the folded position, the rudder assembly 112 is slid within the rudder bearing 506 to ensure that the rudder 502 does not protrude from the hull 102.

[0089] The transom 302 includes bars 602 running along the gunwale 206 of the transom 302. In the middle of the top of the transom 302 is a cut-out 604 for receiving a mount for an auxiliary motor, such as an outboard or trolling motor. Those skilled in the art will recognize that the shape, size, and need for a cut-out will vary depending upon the requirements of the auxiliary motor and can vary without departing from the spirit and scope of the present invention.

[0090] FIG. 7 illustrates an end view of a piece of the corrugated plastic sheet 700. Many portions of the boat 100 are fabricated from a corrugated plastic sheet, which in one embodiment is an extruded twin-wall plastic sheet of high impact polypropylene copolymer, such as Coroplast. The copolymer resin allows the material to repeatedly flex and act as a hinge without breaking or cracking. The sheet 700 has a first surface, or wall, 702 and a second surface, or wall, 704 with a plurality of flutes 706 joining the two surfaces 702, 704 at regular intervals. The flutes 706 are parallel to each other in a spaced apart configuration and perpendicular to the first and second surfaces 702, 704. The first surface 702 and the second surface 704 are thin sheets of plastic. Those skilled in the art will recognize that, when discussing the sheet 700, the first surface 702 and the second surface 704 are interchangeable.

[0091] FIG. 8 illustrates an end view of a channel cut joint 412. FIG. 9 illustrates a front view of the channel cut joint 412. The channel cut joint 412 has a rectangular section of the second surface 704 removed, along with a portion of the flutes 706 adjacent the removed piece of the second surface 704. The channel cut joint 412 has inside side walls 802 and an inside back wall 804, forming a channel in the corrugated sheet 700. The channel cut 412, by virtue of the flutes 706

not being completely cut away at the joint **412**, maintains rigidity of the sheet **700** and prevents the two inside walls **802** from coming together in the plane of the sheet **700** when the sheet **700** is flat.

[0092] The channel cut joint **412** allows the sheet **700** to fold such that the first surface **702** is adjacent to itself and to also fold such that the second surface **704** is adjacent to itself. That is, the joint **412** is a hinge that allows one portion of the sheet **700** to fold in either direction. The channel cut joint **412** is used in the boat **100** where the sheet **700** is folded upon itself and the double layer of sheet **700** is then folded.

[0093] FIG. **10** illustrates a perspective view of a parallel flute half-cut joint **1000**. The parallel flute joint **1000** is a joint formed with the second surface **704** of the sheet cut in a direction parallel to the flutes **706** of the sheet **700**. The parallel flute joint **1000** forms a hinge with the first surface **702** flexing and bending between the flutes **704** on opposite sides of the cut in the second surface **704**. The parallel flute joint **1000** is one type of half-cut joint.

[0094] FIG. **11** illustrates a perspective view of one embodiment of a cross-flute half-cut joint **1100**. FIG. **12** illustrates another perspective view of the cross-flute half-cut joint **1100**. The cross-flute joint **1100** is a joint formed with the second surface **704** and the adjacent flutes **706** cut in a direction substantially perpendicular to the flutes **706** and all the way to the first surface **702**, but not cutting the first surface **702**. The cross-flute joint **1100** forms a hinge with the first surface **702** flexing and bending. The cross-flute joint **1100** is one type of half-cut joint.

[0095] FIG. **13** illustrates a perspective bottom view of a right-angle face cut joint **1300** adjacent the transom **302** showing a stern fold **308**. The face cut joint **1300** is formed by removing a section of the second surface **704** of the corrugated sheet **700** and removing the flutes **706** adjacent to the removed section of the second surface **704**. The first surface **702** remaining in the face cut joint **1300** forms the stern fold **308**, which is a flexible joint that allows a side of the transom **302** to be adjacent the rear edge of the starboard wall **314-S**. A parallel flute joint **1000** between the side wall **314-S** and the remainder of the hull **102** is illustrated perpendicular to the channel cut **412** between the transom **302** and the remainder of the hull **102**.

[0096] Also illustrated in FIG. **13** are the studs **514**, **516** protruding from the ends of the corrugated sheet **700**. In the deployed position, the studs **514**, **516** are linked together, thereby securing the side walls **314** of the hull **102** to the transom **302**. In one embodiment, the studs **514**, **516** are linked by a member with two holes with each hole engaging one of the studs **514**, **516**.

[0097] FIG. **14** illustrates a bottom plan view of an angled face cut joint **1400** at the bow **304** of the boat **100** showing a forward fold **306**, where the second surface **704** and a portion of the flutes **706** have been removed. The first surface **702** remaining in the face cut joint **1400** forms a forward fold **306**, which is a flexible joint that allows a side of the forward panel **404** to be adjacent the forward edge of the starboard wall **314-S** when the hull **102** is in the deployed position.

[0098] Also illustrated in FIG. **14** are the studs **522**, **524** protruding from the ends of the corrugated sheet **700**. In the deployed position, the studs **522**, **524** are linked together, thereby securing the forward panel **404** of the hull **102** to the side walls **314** of the hull **102**. In one embodiment, the studs

522, **524** are linked by a member with two holes with each hole engaging one of the studs **522**, **524**.

[0099] The illustrated joints **412**, **1000**, **1100**, **1300**, **1400** in the corrugated sheet **700** allow the various components of the boat **100** to assume the deployed shape as illustrated in FIGS. **1-6** and to also assume the folded shape illustrated in the later figures. The channel cut joint **412** allows for a wide hinge joint and also allows for a hinge that flexes two ways. The parallel flute joint **1000** and the cross-flute joint **1100** form hinges with a well-defined hinge line, although the hinge line of the parallel flute joint **1000** is wider than that of the cross-flute joint **1100**, which is constrained by the cut flutes **706**. The face cut joints **1300**, **1400** are joints that flex and bend such that the material of the first surface **702** is positioned out of the way as the sheet **700** is placed in various positions and configurations. The edges of the sheet **700** adjacent the face cut joint **1300**, **1400** are minimally constrained from moving, that is, the first surface **702** in the joint **1300**, **1400** that forms the folds **306**, **308** allow the sheet **700** to fold and form an inside corner with three walls. Stability of the walls adjacent the joints **1300**, **1400** is provided by securing the bow **304** with the corresponding pair of studs **522**, **524** linked together and by securing the transom **302** with the corresponding pair of studs **516**, **514** linked together.

[0100] FIG. **15** illustrates a perspective view of the seat **104** in the deployed position. FIG. **16** illustrates a perspective view of the seat **104**. FIG. **17** illustrates a perspective bottom view of a partially folded seat **104**. FIG. **18** illustrates a side view of a seat **104** in the folded position. The seat back **122**, the seat bottom **222**, and the arm rests **124** are made of a base layer of corrugated sheet **700** and an upper layer **1502** that is a soft, resilient material, such as a foam. An upper layer **1502** of closed-cell foam provides comfort and also provides flotation because it displaces water.

[0101] The seat back **122** and seat bottom **222** has a hinge joint **1504** that includes two closely spaced cross-flute joints **1100** that allow the seat back **122** and bottom **222** to hinge in two directions. In one direction, the seat **104** is deployed and in the other direction, illustrated in FIGS. **17** and **18**, the seat **104** is folded with the base layers **700** adjacent.

[0102] The seat frame **224** has four connectors **1512** that mate with the connectors **226** on the hull **102**. The two connectors **1512** attached to the arm rest **124** adjacent the tiller **126** have bushings that allow the tiller **126** to rotate. The tiller **126** is illustrated in various rotated positions in FIGS. **15-18**. The Tiller **126** is dimensioned and configured to be grasped in one hand and rotated to cause the rudder **112** to rotate within the rudder bearing **506**.

[0103] FIG. **19** illustrates a view of another embodiment of a paddle assembly **106'**. The opposite ends of the crankshaft **134** have bearing connectors **202**. The bearing connector **202** has a bushing that allows the crankshaft **134** to rotate and the bearing connector **202** also has an interface to the connector **204** on the hull **102**. The pedals **132** freely rotate on the crankshaft **134**. The illustrated embodiment of the paddle assembly **106'** has a pair of paddles **136'** each with only two blades, or paddle blades, **1904** attached to a paddle strut, or shaft, **1902**. The paddles **136'** are illustrated in the deployed position.

[0104] FIG. **20** illustrates a partial view of one embodiment of a paddle **136'**. The blades **1904** pivot about a shaft **2002** that secures the paddle **1904** to the shaft **1902**. The paddle **1904** has a pair of protrusions **2004** that engage

depressions or holes **2006** in a shaft end-piece **2008**. The blade **1904** is illustrated in the deployed position. In the folded position, the blade **1904** rotates **2012** such that the blade **1904** does not protrude outboard of the shaft, or strut, **1902**.

[0105] FIG. **21** illustrates a perspective partially exploded view of one embodiment of the deployed paddle assembly **106** as illustrated in FIGS. **1** and **2**. The two paddles **136** are detachable from the crankshaft **134** at a shaft connector **2102** by removing a pin **2104**. Each paddle **136** includes a pair of paddle shafts **2112**, **2122** with a blade **2106** fixed at each end. The blades **2106** are attached to the shafts **2112**, **2122** in a fixed position.

[0106] FIG. **22** illustrates a side view of a paddle **136** in the deployed, or operating, position. FIG. **23** illustrates a side view of a paddle **136** in a folded, or storage, position. The inboard shaft **2112** rotates relative to the outboard shaft **2122** by virtue of the folding mechanism **2108**. In the deployed position, the two shafts **2112**, **2122** of the paddle **136** are perpendicular to each other. In the folded position, the two shafts **2112**, **2122** are approximately parallel to each other with the paddles **2106** on each shaft **2112**, **2122** adjacent to each other.

[0107] FIG. **24** illustrates an exploded view of the paddle folding mechanism **2108**. The midpoint of the outboard shaft **2122** is attached to a first shaft **2402** that fits within a second shaft **2404** that is attached to the midpoint of the inboard shaft **2112**. The first shaft **2402** has a pair of holes **2420** at the end opposite its connection to the outboard shaft **2122**. The second shaft **2404** has a pair of holes **2422** at the end opposite the end adjacent the outboard shaft **2122**. The two pairs of holes **2420**, **2422** are aligned when the paddle **136** is in the deployed position. Shaft connector **2102** also has a pair of holes **2424** that, when aligned with the two pairs of holes **2402**, **2424** in the first and second shafts **2402**, **2404**, receive pin **2104** to secure the shafts **2402**, **2404** in the connector **2102**. The pin **2104** is stored in the connector **2102** when the boat **100** is in the folded configuration.

[0108] The second shaft **2404** has a slot **2412** and the first shaft has an opening **2416** and a threaded fastener **2414** that engages the opening **2416**. When the first and second shafts **2402**, **2404** are engaged, the threaded fastener **2414** secured to the first shaft **2412** is within the confines of the slot **2412** in the second shaft **2404**, thereby preventing the second shaft **2404** from rotating beyond a certain point relative to the first shaft **2402**. In other words, the slot **2412** and fastener **2414** combination function as a rotation stop and as a keeper to ensure that the two shafts **2402**, **2404** do not separate.

[0109] In one embodiment, the blades **1904**, **2106** are not perpendicular to the longitudinal axis of the boat **100** when the blades **1904**, **2106** are at their lowest point and in the water. The blades **1904**, **2106** are angled such that any spray kicked up by the blades **1904**, **2106** as they are operated is directed away from the boat **100** and its occupant.

[0110] FIG. **25** illustrates a bottom view of the canopy **108** in the partially folded position. The illustrated canopy **108** has the side curtains **238** flat and the support poles **232** folded against the canopy cross-piece **2502**. The canopy cross-piece **2502** is a member that extends across the width of the canopy **108** and has swiveling connections to each support pole **232**. The canopy cross-pieces **2502** are attached to the underside of the canopy **108** at each end of the canopy **108**.

[0111] The canopy **108** has two channel cut joints **412** athwartships that divide the canopy **108** into thirds. Each channel cut joint **412** is on opposite sides of the sheet **700** making the canopy **108**. Between the center of the canopy **108** and the side curtains **238** are parallel flute joints **1000** and between the center of the canopy **108** and the aft curtain **236** is a cross-flute joint **1100**.

[0112] FIG. **26** illustrates a side view of the canopy **108** in the deployed position. The support poles **232** are rotated down. The side curtains **238** hinge downward from the parallel flute joints **1000**, and the aft curtain hinges downward from the cross-flute joint **1100**. The side curtains **238** are placed in tension and provide support in the stern-to-bow direction and prevent the canopy **108** from drooping.

[0113] FIG. **27** illustrates a side view of the canopy **108** in the folded position. After the canopy **108** is placed in the partial folded position as illustrated in FIG. **25**, the side curtains **238** are folded in and positioned adjacent the center portion of the sheet **700** forming the canopy **108**. The canopy **108** is then folded into thirds with the center section **2508** of the canopy **108** being in the center with each of the end sections on opposite sides of the center section **2508**.

[0114] FIGS. **28** to **35** illustrate the steps in folding the boat **100** from the deployed position to the fully-folded position. The deployed position is one in which the boat **100** assumes a boat-shape as illustrated in FIG. **1**. The fully-folded position is one in which the boat **100** assumes a box-shape as illustrated in FIG. **35**.

[0115] FIG. **28** illustrates a perspective view of the hull **102** in the deployed position. The rudder assembly **112** is in the upper position because the hull **102** is resting on a surface ready to be folded. At the bow **304** the link **2802** connecting the stud **524** in the forward panel **404** to the stud **522** in the starboard wall **314-S** is illustrated. At the transom **302** the link **2804** connecting the stud **516** in the transom **302** to the stud **514** in the starboard wall **314-S** is illustrated.

[0116] FIG. **29** illustrates a perspective view of the hull **102** with the forward panel section **404** released from the deployed position exposing the forward folds **306**. The link **2802** connecting the two studs **522**, **524** on each side of the bow **304** is disconnected from the stud **524** in the forward panel section **404**. The face cut joint **1400** between the side walls **314** and the forward panel section **404** opens and spreads the forward folds **306**, allowing the forward panel section **404** to drop down and lie in the same plane as the bottom of the hull **102**. The rear link **2804** connecting the two aft studs **514**, **516** on each side of the transom **302** is disconnected from the stud **514** in the side wall **314**. The face cut joint **1300** between the transom **302** and the side wall **314** begins to open.

[0117] FIG. **30** illustrates a perspective view of the hull **102** in the partially folded position with the side walls **314** folded. With the links **2802**, **2804** disconnected, the side walls **314** fold inward and lie adjacent the inside bottom of the hull **102**.

[0118] FIG. **31** illustrates a perspective view of the boat **100** in the partially folded position with the four modules **102**, **104**, **106**, **108** positioned together. With the side walls **314** folded inward, the canopy **108** and the seat **104** are positioned adjacent the transom **302**. Those skilled in the art will recognize that the order of placing the canopy **108** and the seat **104** adjacent the transom **302** can vary without departing from the spirit and scope of the present invention. The paddle assembly **106** is positioned amidships.

[0119] FIG. 32 illustrates a perspective view of the boat 100 in the partially folded position with the forward end of the hull 102 folded over the paddle assembly 106. The forward end of the forward panel section 404 is lifted and swung 3202 up to a standing position, ready to swing over the paddle assembly 106.

[0120] FIG. 33 illustrates a perspective view of the boat 100 in the partially folded position with the midship and forward end of the hull 102 folded. The portion of the boat 100 that is folded around the paddle assembly 106 and is standing upright is swung 3302 over the canopy 108 and the seat 104.

[0121] FIG. 34 illustrates a perspective view of the boat 100 in the folded position resting on a side of the folded box-shape. The portion of the boat 100 that is folded around the paddle assembly 106 is lifted and swung 3302 over the canopy 108 and the seat 104. The rear link 2804 is ready to connect the stud 518 in the hull 102 to the stud 516 in the transom 302. The brace 512 between the transom 302 and bottom of the hull 102 fixes two walls of the box-shaped folded boat 100.

[0122] FIG. 35 illustrates a perspective view of one embodiment of the boat 100 in the fully-folded position resting on the bottom 3502-B. The fully-folded position of the boat 100 is one that includes four walls 3502 that form a box-shape or a suitcase-shape. The boat 100 in the fully-folded position has a top wall 3502-T, two sides 3502-S, and a bottom 3502-B. The handle 114 is on the top wall 3502-T.

[0123] In the illustrated embodiment, the ends are open, exposing the modules 104, 106, 108, which are secured inside the folded hull 102 by the folded configuration of the hull 102. In one embodiment, the fully-folded boat 100 is fitted inside a flexible cover or bag that is secured around the handle 112. In another embodiment, the fully-folded boat 100 includes shoulder straps that allow the fully-folded boat to be carried as a backpack.

[0124] The rear link 2804 connects the stud 518 in the hull 102 to the stud 516 in the transom 302, thereby securely wrapping the hull 102 around the other three modules 104, 106, 108. The embodiment illustrated in FIGS. 28-35 does not have a pair of wheels 116 and a pair of legs 118 attached to the hull. The illustrated embodiment is configured to be picked up and carried by the handle 112.

[0125] FIG. 36 illustrates a side perspective view of another embodiment of the boat 100 in the fully folded position showing a wheel 116 and a leg 118. The illustrated embodiment is either picked up and carried by the handle 112 or tilted and rolled on the wheels 116.

[0126] FIG. 37 illustrates a close-up view of a latching connection of the boat 100 in the fully folded position. Another embodiment of the rear link 2804' is shown in phantom to show the studs 516, 518'. The illustrated rear link 2804' is a section of tubing with openings positioned to engage the two studs 516, 518. Adjacent the hole engaging the stud 518' is another hole 3702 for engaging the stud 514 attached to the side wall 314. In one embodiment, the studs 514, 516, 518, 522, 524 are fasteners that are threaded, or screwed, into the flutes 706 of the corrugated sheet 700. In the illustrated embodiment, the rear link 2804' is longer than the link 2804 illustrated in FIG. 36 in order to reach the stud 518' on the sidewall 3502-S. The stud 518 illustrated in FIG. 36 is secured in the top 3502-T.

[0127] The sheet 700 adjacent the channel cut joints 412 where the sidewalls 314 are folding onto the deck 316 are illustrated in a side view in FIG. 37. The channel cut joints 412 exposed on the outside of the hull 102 in the fully folded position, in one embodiment, have a protective strip 3602 inserted into slits 3604 cut into the flutes 706 adjacent the inside walls 802 of the channel cut joint 412. The strips 3602 cover the exposed flutes 706 that are cut to form the channel cut joint 412. With sufficient depth of the slits 3604, the strips 3602 remain in place as the boat 100 is repeatedly deployed and folded.

[0128] Those skilled in the art will recognize that the location and position of the channel cut joints 412 in the hull 102 can be varied to accommodate the number and size of the modules 104, 106, 108 desired to be used with the hull 102 without departing from the spirit and scope of the present invention. For example, if the paddle assembly 106 is not desired, the location of the channel cut joints 412 in the hull 102 can be varied such that the folded boat 100 securely encompasses the remaining modules, which may include the seat 104 and the canopy 108.

[0129] FIG. 38 illustrates a perspective view of another embodiment of a cross-flute half-cut joint 1100'. FIG. 39 illustrates a side view of the second embodiment of a cross-flute half-cut joint 1100'. The illustrated embodiment of the cross-flute joint 1100' is a joint formed with the second surface 704 having a cut 3902 a direction substantially perpendicular to the flutes 706 and the adjacent flutes 706 having a pair of cuts 3904 with an inverted V-shape with the apex at the cut 3902 on the second surface 704. The illustrated cross-flute joint 1100' forms a hinge with the first surface 702 flexing and bending to form a U-shaped cavity 4002 between the adjacent first surfaces 702 when the corrugated sheet 700 is folded over as illustrated in FIG. 39. The pair of cuts 3904 have two edges 3904-A, 3904-B that separate and allow the bending stress to be dispersed of a wider area than the embodiment of the cross-flute joint 1100 illustrated in FIGS. 11 and 12.

[0130] FIG. 40 illustrates a top plan view of another embodiment of the hull 102' in the deployed position. The illustrated boat hull 102' has a pointed, or blunt-nosed, bow 304' compared to the hull 102 illustrated in FIG. 3, which has a pram's square bow 304. Additionally, the sidewalls 314-S, 314-P and the transom 302 are sloped outward.

[0131] FIG. 41 illustrates a bottom plan view of another embodiment of a face cut 1300' at the bow 304' of the hull 102' with the hull 102' in a flattened, or planar, position. The forward panel 404', unlike the rectangular panel 404 illustrated in FIG. 14, has a trapezoidal shape that is narrower at the forward end than at the aft end. When the adjacent edges of the forward panel 404' and the forward side panels 314-P, 314-S are brought together, the excess portion of the first surface 702 where the second surface 704 and a portion of the flutes 706 have been removed forms the forward fold 306' that is gathered inside the hull 102'.

[0132] FIG. 42 illustrates a bottom plan view of another embodiment of a face cut 1400' adjacent the transom 302. The face cut 1400' is bounded by two edges 4202, 4204 that enable the sidewalls 314 and the transom 302 to have an outward slope when the hull 102' is in the deployed position.

[0133] The forward connectors 204, 204', because of the pointed bow 304', are separated with varying gaps. That is, the forward connectors 204 positioned on the portion of the sidewalls 314 that are parallel have the same athwartship

gap that the seat connectors **226** and canopy connectors **234** have. The forward connectors **204'** positioned on the side-walls **314** in the bow **304'** are progressively closer together the more forward the connectors **204'** are located. The forward connectors are positioned to allow the paddle assembly **106** to be positioned fore and aft relative to the seat **104** in order to accommodate the operator comfortably. In order for the paddle assembly **106** to be secured to the hull **102'**, in one embodiment, the connector halves **202** on the paddle assembly **106** are adjustable athwartships to accommodate the varying distance between corresponding connectors **204, 204'**.

[0134] The boat **100** includes various functions. The function of maintaining a floating hull **102, 102'** is implemented, in one embodiment, by the single corrugated plastic sheet **700** that has integral joints **412, 1000, 1100, 1100', 1300, 1300', 1400, 1400'** and an unbroken first surface **702** in the portion of the hull **102, 102'** that is exposed to the water in which the hull **102, 102'** floats.

[0135] The function of forming a floating hull **102, 102'** is implemented, in one embodiment, by the corrugated sheet **700** with the various channel cut joints **412**, parallel and cross flute joints **1000, 1100, 1100'**, and face joints **1300, 1300', 1400, 1400'** cut into the sheet **700** without puncturing or penetrating one surface **702** of the sheet **700**. The function of maintaining the shape of the hull **102, 102'** is implemented, in one embodiment, by the rear link **2804** engaging the aft studs **514, 516** and the forward link **2802** engaging the forward studs **522, 524**. The function of maintaining the box-shape of the folded boat **100** is implemented, in one embodiment, by the rear link **2804** engaging the studs **516, 518**. The function of bendable joints with lateral stability is implemented, in one embodiment, by the channel cut joints **412**, the parallel flute joints **1000**, and the cross-flute joints **1100, 1100'**.

[0136] The function of providing motive force is implemented, in one embodiment, by the paddle assembly **106, 106'**. The function of protecting the occupant from the elements is implemented, in one embodiment, by the canopy **108**.

[0137] From the foregoing description, it will be recognized by those skilled in the art that a folding boat **100** has been provided. The folding boat **100** is formed from a single sheet **700** of corrugated plastic with one intact first surface **702** and an opposing surface **704** that is cut away to form various hinges, or joints, **412, 1000, 1100, 1100', 1300, 1300', 1400, 1400'**. In some cases the hinges **412** fold in both directions, and in other cases the hinges **1000, 1100', 1100** fold in one direction, that is, folding the sheet **700** causes only one surface **702** of the sheet **700** to become adjacent to itself.

[0138] While the present invention has been illustrated by description of several embodiments and while the illustrative embodiments have been described in considerable detail, it is not the intention of the applicant to restrict or in any way limit the scope of the appended claims to such detail. Additional advantages and modifications will readily appear to those skilled in the art. The invention in its broader aspects is therefore not limited to the specific details, representative apparatus and methods, and illustrative examples shown and described. Accordingly, departures may be made from such details without departing from the spirit or scope of applicant's general inventive concept.

What is claimed is:

1. An apparatus for use on water that is foldable into a compact shape for transport, said apparatus comprising:
 - a sheet of corrugated material having a generally rectangular shape, said sheet foldable into a first configuration in which said sheet assumes a hull-shape, said sheet foldable into a second configuration in which said sheet assumes a box-shape,
 - in said first configuration said sheet includes a deck, a transom, and a pair of sidewalls, said deck joined to each of said pair of sidewalls and said transom by a first joint,
 - in said second configuration said sheet includes a top, a bottom, and a pair of sidewalls, said sheet having a plurality of second joints connecting said top, said bottom, and said pair of sidewalls, in said second configuration said pair of sidewalls are folded to be positioned adjacent said deck; and
 - a cross-member releaseably attachable to each one of said pair of sidewalls adjacent a gunwales of each of said pair of sidewalls when said sheet is in said first configuration, said member bridging said pair of sidewalls.
2. The apparatus of claim 1 further including a seat having at least one cross-member dimensioned and configured to releaseably attach to each one of said pair of sidewalls when said sheet is in said first configuration.
3. The apparatus of claim 1 further including a rudder attached to said sheet in said first configuration, said rudder having an operator accessible from a seat releaseably attachable to said sheet when in said first configuration.
4. The apparatus of claim 1 further including a drive mechanism having a crankshaft dimensioned and configured to extend beyond each one of said pair of sidewalls when said sheet is in said first configuration, said crankshaft releaseably connected to each one of said pair of sidewalls wherein said crankshaft is free to rotate about an athwartships axis, said drive mechanism having a first pair of paddles each of which are attached to a corresponding end of said crankshaft.
5. The apparatus of claim 4 wherein said first pair of paddles each include a strut and a pair of blades, a midsection of each strut connected to said crankshaft, each one of said pair of blades rotateably attached to each end of said strut, each one of said pair of blades having an extended position configured for said first configuration of said sheet and a folded position configured for said second position of said sheet.
6. The apparatus of claim 4 wherein said first pair of paddles each include a first strut and a first pair of blades, each one of said first pair of blades attached to an end of said first strut, and further including a second pair of paddles each including a second strut and a second pair of blades, each one of said second pair of blades attached to an end of said second strut, each one of said first struts cooperatively connected to a corresponding one of said second struts, each one of said first and second struts having a deployed position in which said first and second struts are substantially perpendicular and having a folded position in which each said first and second struts are coplanar.
7. The apparatus of claim 1 further including a canopy of corrugated material supported by a frame, said frame releaseably connected to said sheet when said sheet is in said first configuration, said canopy foldable into a first canopy configuration in which said canopy has a top with a set of legs extending between said top and said sheet, and said

canopy foldable into a second canopy configuration in which said canopy assumes a substantially planar shape.

8. An apparatus for use on water that is foldable into a compact shape for transport, said apparatus comprising:

a sheet of corrugated material having a generally rectangular shape, said corrugated material having a first surface, a second surface, and a plurality of parallel flutes connecting said first and second surfaces, said sheet foldable into a first configuration in which said sheet assumes a hull-shape, said sheet foldable into a second configuration in which said sheet assumes a box-shape,

in said first configuration said sheet includes a deck, a transom, and a pair of sidewalls, said deck joined to each of said pair of sidewalls and said transom by a first joint, and

in said second configuration said sheet includes a top, a bottom, and a pair of sidewalls, said sheet having a plurality of second joints connecting said top, said bottom, and said pair of sidewalls, in said second configuration said pair of sidewalls are folded to be positioned adjacent said deck,

each said second joint having a channel defined by said first surface, a portion of said plurality of flutes attached to said first surface, and a pair of edges of said second surface, each said second joint being a hinge with a first position in which said first surface of said corrugated material on opposite sides of said second joint are adjacent and with a second position in which said second surface of said corrugated material on said opposite sides of said second joint are adjacent.

9. The apparatus of claim 8 further including a cross-member releaseably attachable to each one of said pair of sidewalls adjacent a gunwales of each of said pair of sidewalls when said sheet is in said first configuration, said member bridging said pair of sidewalls.

10. The apparatus of claim 8 further including a seat having at least one cross-member dimensioned and configured to releaseably attach to each one of said pair of sidewalls when said sheet is in said first configuration.

11. The apparatus of claim 8 further including a rudder attached to said sheet in said first configuration, said rudder having an operator accessible from a seat releaseably attachable to said sheet when in said first configuration.

12. The apparatus of claim 8 further including a drive mechanism having a crankshaft dimensioned and configured to extend beyond each one of said pair of sidewalls when said sheet is in said first configuration, said crankshaft releaseably connected to each one of said pair of sidewalls wherein said crankshaft is free to rotate about an athwartships axis, said drive mechanism having a first pair of paddles each of which are attached to a corresponding end of said crankshaft.

13. The apparatus of claim 12 wherein said first pair of paddles each include a strut and a pair of blades, a midsection of each strut connected to said crankshaft, each one of said pair of blades rotateably attached to each end of said strut, each one of said pair of blades having an extended position configured for said first configuration of said sheet and a folded position configured for said second position of said sheet.

14. The apparatus of claim 12 wherein said first pair of paddles each include a first strut and a first pair of blades, each one of said first pair of blades attached to an end of said

first strut, and further including a second pair of paddles each including a second strut and a second pair of blades, each one of said second pair of blades attached to an end of said second strut, each one of said first struts cooperatively connected to a corresponding one of said second struts, each one of said first and second struts having a deployed position in which said first and second struts are substantially perpendicular and having a folded position in which each said first and second struts are coplanar.

15. The apparatus of claim 8 further including a canopy of corrugated material supported by a frame, said frame releaseably connected to said sheet when said sheet is in said first configuration, said canopy foldable into a first canopy configuration in which said canopy has a top with a set of legs extending between said top and said sheet, and said canopy foldable into a second canopy configuration in which said canopy assumes a substantially planar shape.

16. An apparatus for use on water that is foldable into a compact shape for transport, said apparatus comprising:

a sheet foldable into a first sheet configuration in which said sheet assumes a hull-shape, said sheet foldable into a second sheet configuration in which said sheet assumes a box-shape, in said first sheet configuration said sheet includes a deck, a transom, and a pair of sidewalls; and

a drive mechanism having a crankshaft and a pair of paddles, said crankshaft dimensioned and configured to extend beyond each one of said pair of sidewalls when said sheet is in said first sheet configuration, said crankshaft releaseably connected to each one of said pair of sidewalls wherein said crankshaft is free to rotate about an athwartships axis, a pair of pedals positioned on opposite sides of said athwartships axis whereby alternating foot pressure applied to said pedals causes said crankshaft to rotate,

said pair of paddles having a first paddle configuration in which said pair of paddles are configured to drive said sheet when said sheet is in said first sheet configuration, and

said pair of paddles having a second paddle configuration in which said pair of paddles are configured to fit in said box-shape when said sheet is in said second sheet configuration.

17. The apparatus of claim 16 further including a seat having at least one cross-member dimensioned and configured to releaseably attach to each one of said pair of sidewalls when said sheet is in said first configuration.

18. The apparatus of claim 16 wherein in said drive mechanism attaches to said sheet at one of a plurality of positions when said sheet is in said first sheet configuration.

19. The apparatus of claim 16 wherein in said first paddle configuration has a blade rotated in a deployed position and said second paddle configuration has a blade rotated into a folded position.

20. The apparatus of claim 16 wherein each one of said pair of paddles includes a first strut and a second strut with each one of said first and second struts having a blade attached at each end, said first paddle configuration is a deployed position in which said first and second struts are substantially perpendicular, and said second paddle configuration is a folded position in which each said first and second struts are coplanar.