



US 20100184528A1

(19) **United States**

(12) **Patent Application Publication**

**Papa, JR.**

(10) **Pub. No.: US 2010/0184528 A1**

(43) **Pub. Date: Jul. 22, 2010**

(54) **DEVICE FOR IMPROVING A GOLF SWING**

**Publication Classification**

(76) Inventor: **Carl Papa, JR.**, Knoxville, TN (US)

(51) **Int. Cl.**  
*A63B 69/36* (2006.01)  
(52) **U.S. Cl.** ..... **473/269**

Correspondence Address:  
**PITTS AND BRITTIAN P C**  
**P O BOX 51295**  
**KNOXVILLE, TN 37950-1295 (US)**

(57) **ABSTRACT**

Described is a portable and intuitive golf swing improvement device for indicating the proper shift of a golfer's body weight to the front foot during a down swing. More specifically, the swing improvement device measures the shift of the golfer's body weight during a golf swing and indicates when such shift is in accordance with a technically sound swing. Additionally, the swing improvement device is self-sufficient and portable such that the device is deployable almost anywhere. The swing improvement device also provides swing analysis in a manner that is immediately understandable to the golfer.

(21) Appl. No.: **12/356,127**

(22) Filed: **Jan. 20, 2009**

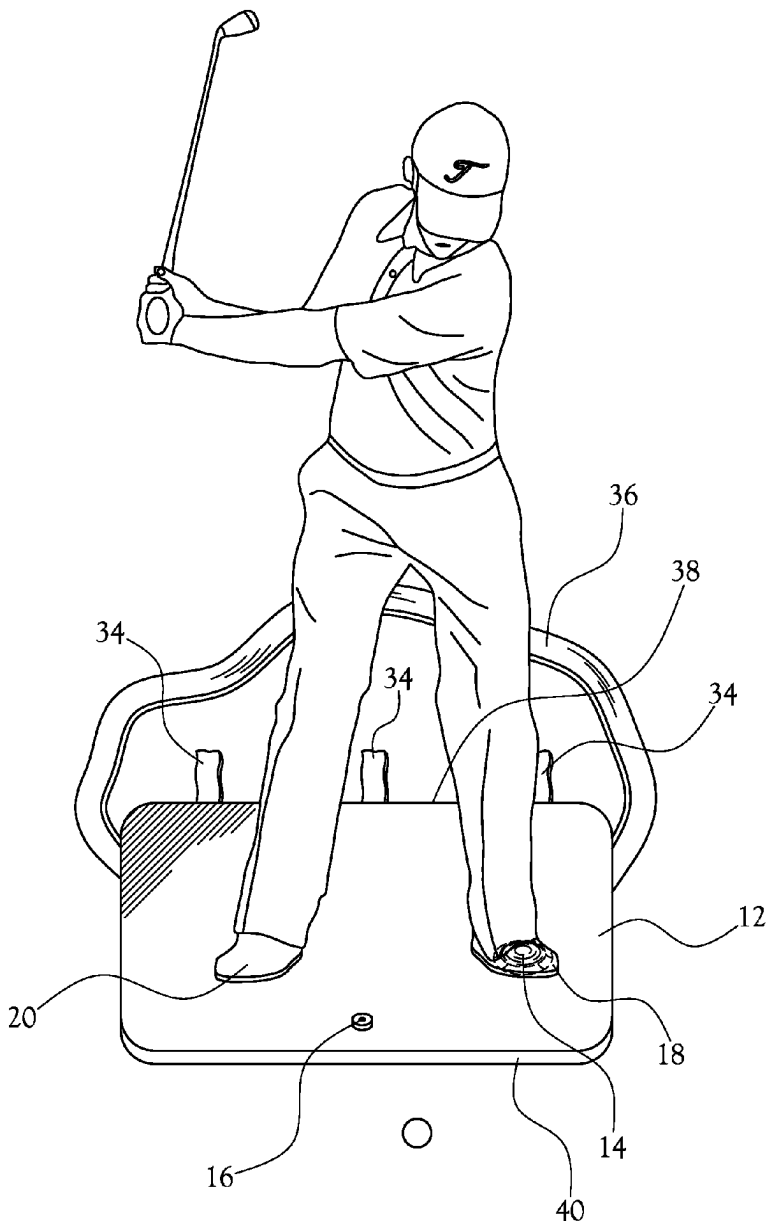

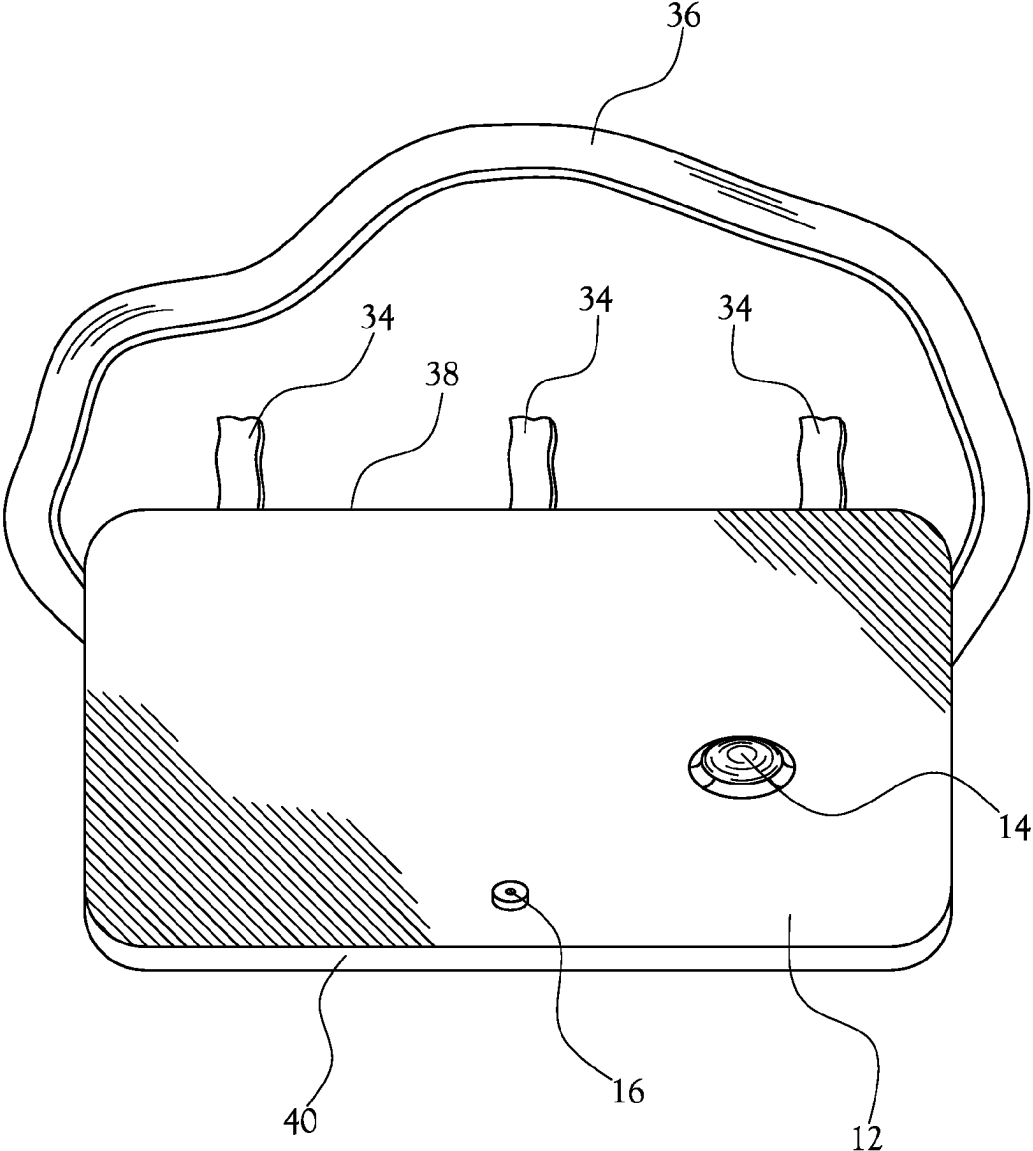

Fig. 1

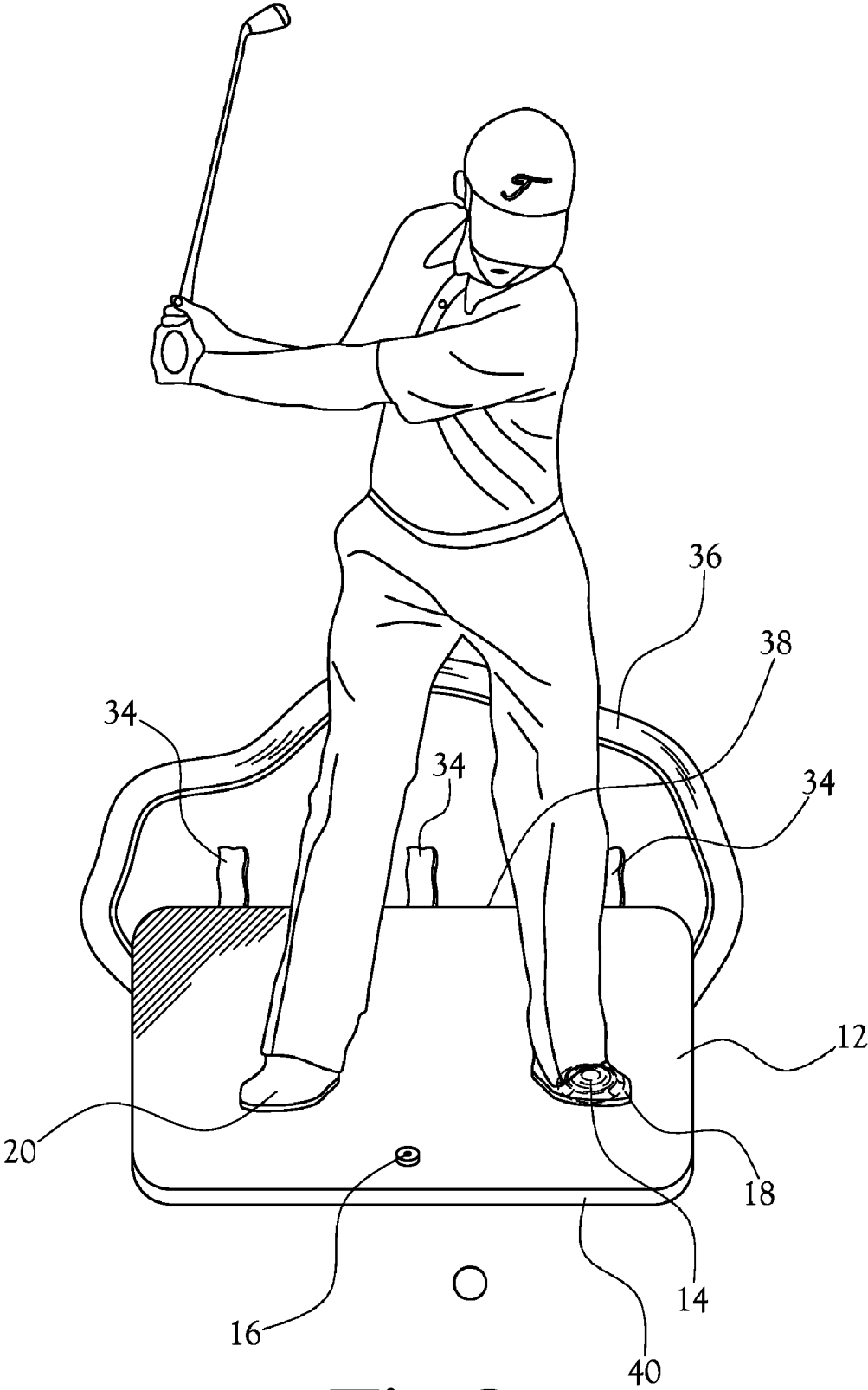

Fig.2

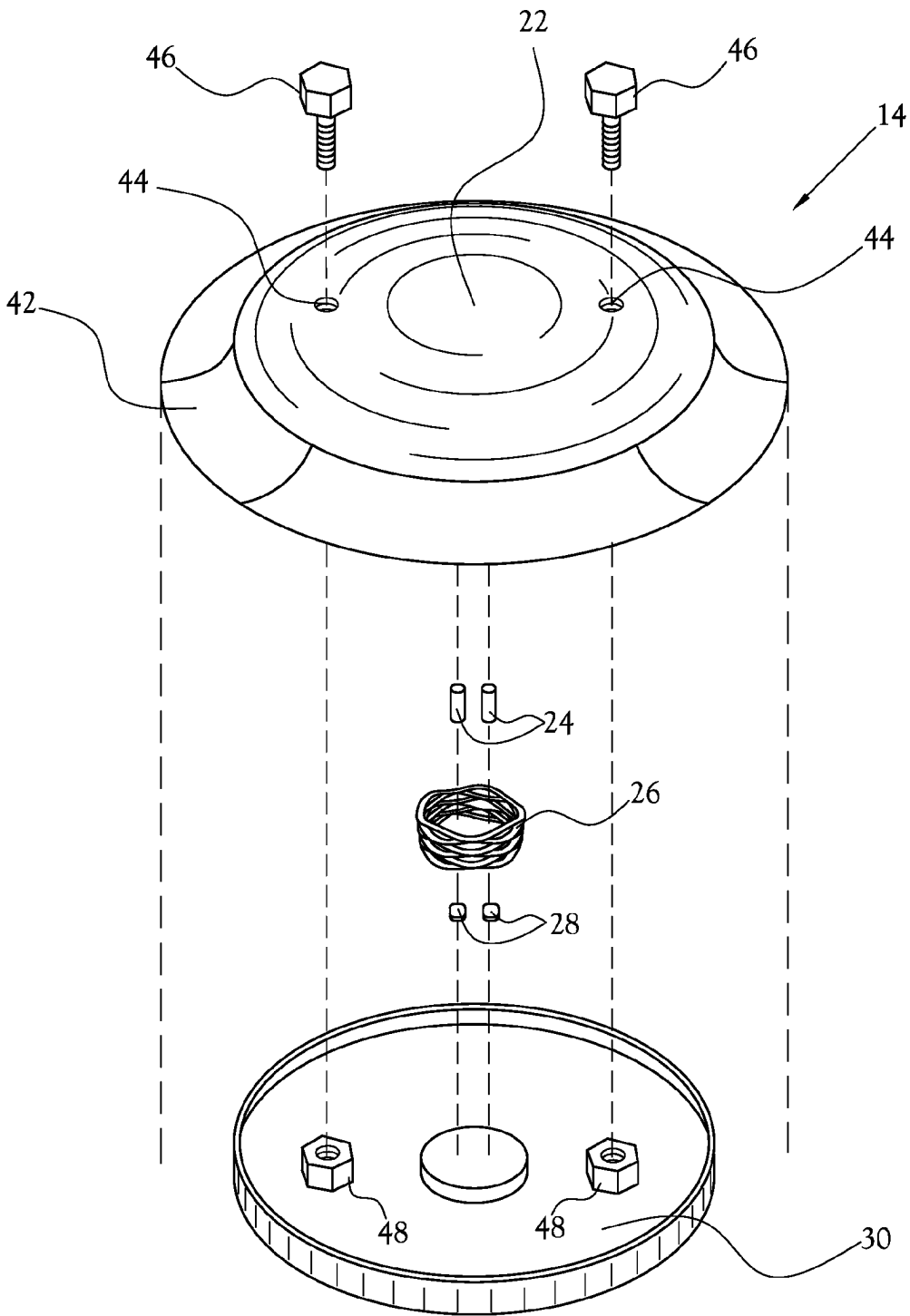

Fig.3

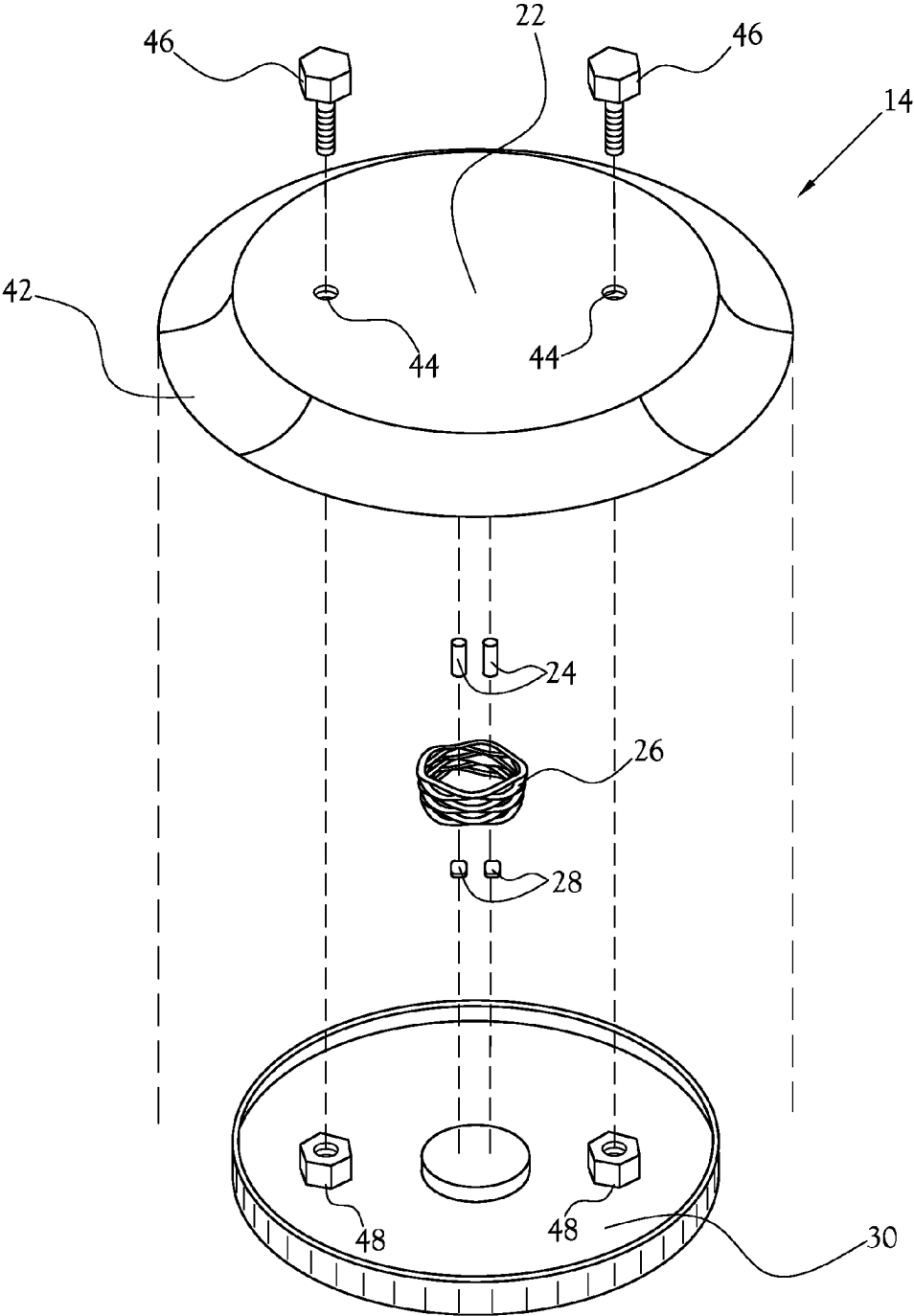

Fig.4

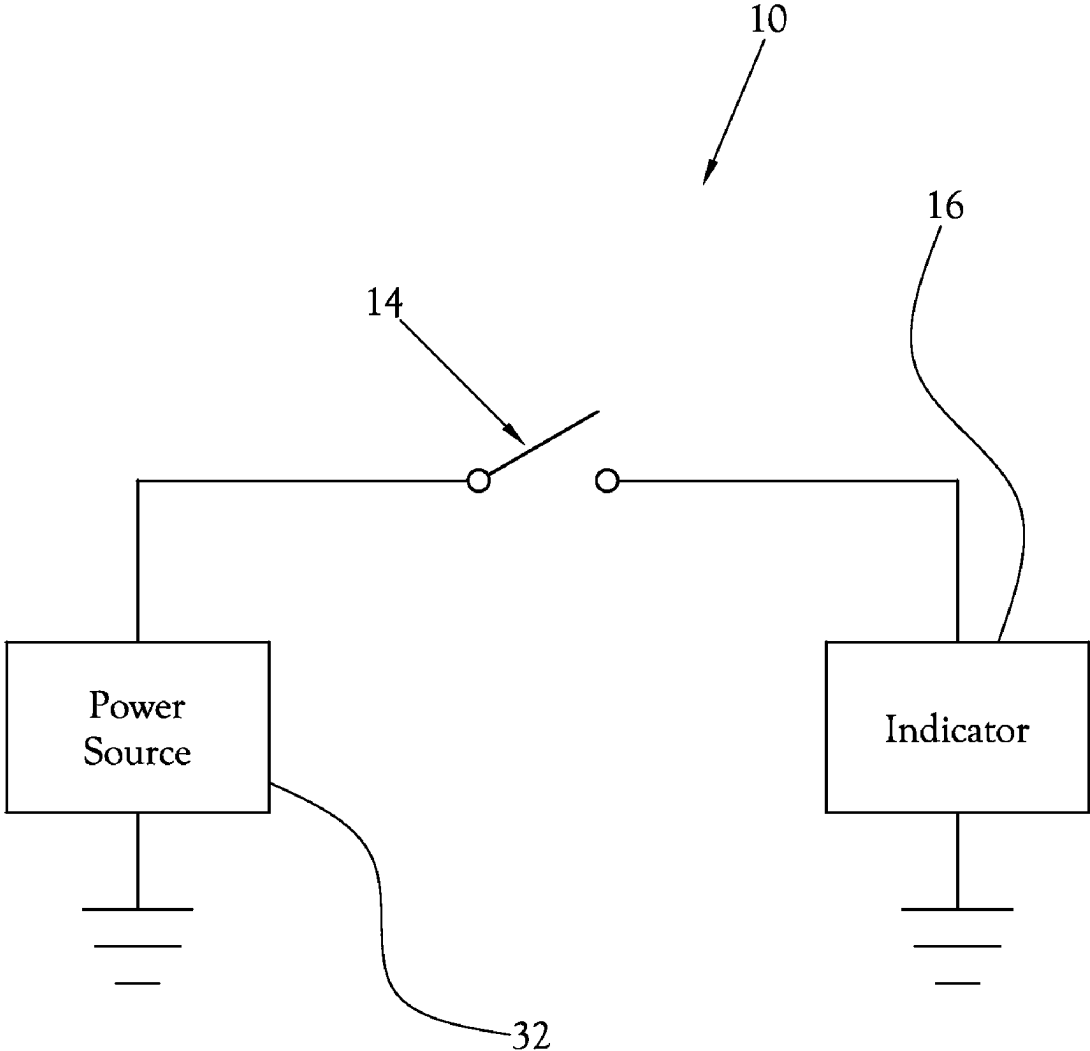

Fig.5

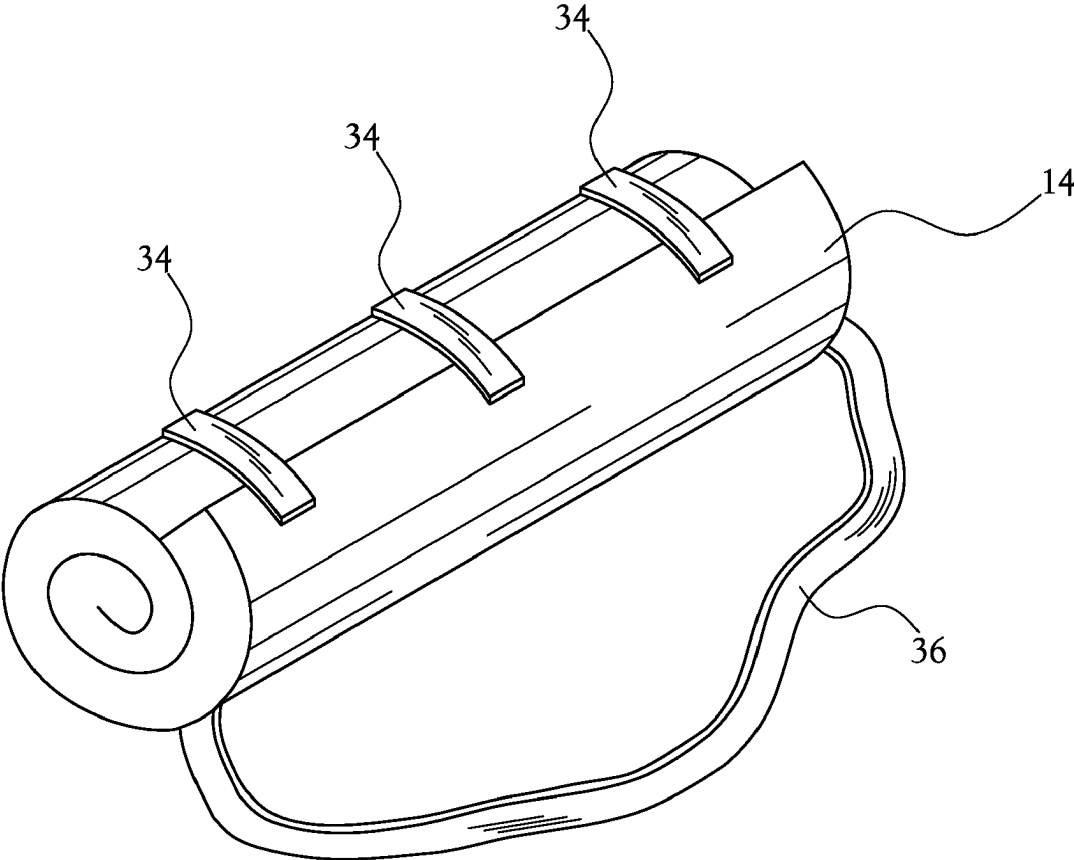

Fig.6

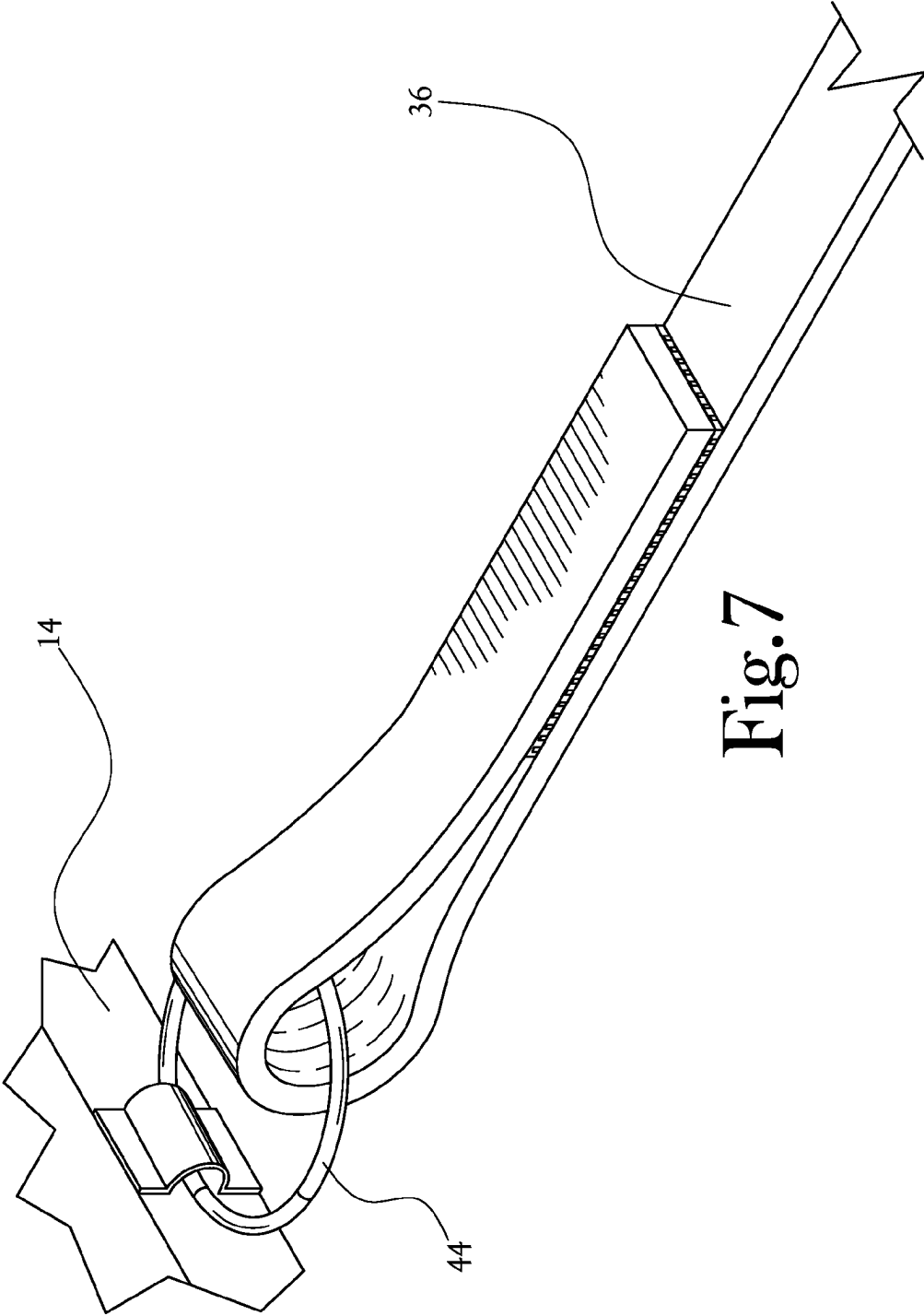

Fig. 7



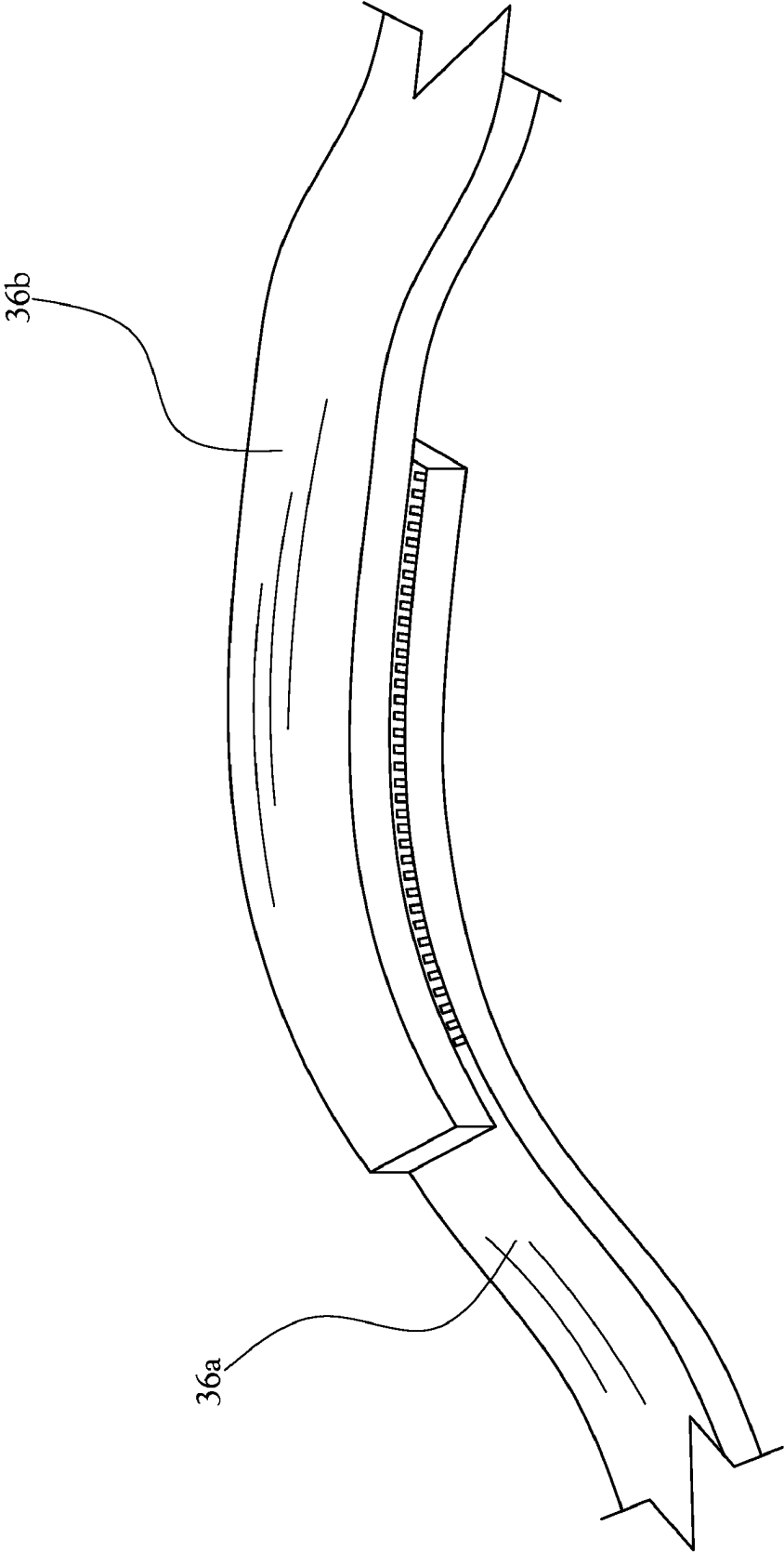

Fig. 8

**DEVICE FOR IMPROVING A GOLF SWING**

**CROSS-REFERENCE TO RELATED APPLICATIONS**

[0001] Not Applicable

**STATEMENT REGARDING FEDERALLY SPONSORED RESEARCH OR DEVELOPMENT**

[0002] Not Applicable

**BACKGROUND OF THE INVENTION**

[0003] 1. Field of the Invention

[0004] This invention pertains to a device for improving a golf swing. More particularly, this invention pertains to a device for indicating the proper shift of a golfer's body weight during the down swing and follow-through of a golf swing.

[0005] 2. Description of the Related Art

[0006] Many golfers, both amateur and professional, are constantly in search of a consistent and technically sound golf swing. One essential component of a technically sound golf swing is the shift of the golfer's body weight to the front foot during the golfer's down swing. As a result, a device that measures this shift of body weight to the front foot would assist in improving a golfer's swing. Many conventional devices measure this shift in body weight using various methods and measurement components and configurations. However, the complexity of these conventional devices requires cumbersome equipment, intricate set-up and operation procedures, extensive signal processing, and complicated data analysis. The cumbersome equipment limits the portability of these conventional devices and the locations at which they can be used. In fact, some conventional devices can only be moved by machine. Additionally, the intricate set-up and operation of these conventional devices limit when the devices can be used. For example, some of these conventional devices require professional instillation, set-up, and operation. The extensive signal processing performed by some of these conventional devices requires an independent computer. This further limits the location at which the devices can be used and requires the purchase of additional equipment. Additionally, the complicated data analysis displayed by some of these conventional devices is cryptic for the average golfer. As a result, one must be trained to read and understand the resulting data analysis of these conventional devices or depend on another for interpretation. Consequently, a device that intuitively indicates the proper shift of a golfer's body weight during a down swing, that is easily operated, and that is portable is desired.

**BRIEF SUMMARY OF THE INVENTION**

[0007] In accordance with the various features of the present invention, there is provided a portable and intuitive golf swing improvement device for indicating the proper shift of a golfer's body weight to the front foot during a technically sound down swing. The swing improvement device includes a mat, a pressure switch, an indicator, a mat securing apparatus, and a transportation apparatus. The mat is sufficiently large such that the golfer is able to take a golfer's stance on the mat. The pressure switch is disposed at the mat such that when the golfer takes a stance on the mat, the golfer's front foot is positioned on the pressure switch. The pressure switch is movable between an open position and a closed position and is biased to the open position by, for example, a spring. The

force of the golfer's front foot against said pressure switch is sufficient to overcome the bias when the golfer shifts its body weight to the front foot in accordance with a technically sound down swing. Accordingly, when the pressure switch moves to the closed position, the indicator generates an indication that is perceivable by the golfer or another, such as an instructor. As a result, when the golfer performs a technically sound golf swing, the indicator generates the indication, which alerts the golfer of a proper swing.

[0008] The mat is capable of a portable position, such as a rolled position. The mat securing apparatus is adapted to cooperate with the mat to maintain the mat at this portable position. The transportation apparatus is secured to the mat such that the swing improvement device can be carried by way of the transportation apparatus. For example, the device can be carried over the shoulder of the golfer or attached to the golfer's bag.

**BRIEF DESCRIPTION OF THE SEVERAL VIEWS OF THE DRAWINGS**

[0009] The above-mentioned features of the invention will become more clearly understood from the following detailed description of the invention read together with the drawings in which:

[0010] FIG. 1 illustrates one embodiment of the golf swing improvement device in accordance with the various features of the present invention;

[0011] FIG. 2 illustrates a golfer performing a golf swing on the swing improvement device of FIG. 1;

[0012] FIG. 3 is an exploded view of one embodiment of the pressure switch having a dome-type housing;

[0013] FIG. 4 is an alternate embodiment of the pressure switch having a flat housing;

[0014] FIG. 5 is a schematic diagram of one embodiment of the swing improvement device in accordance with the various features of the present invention;

[0015] FIG. 6 illustrates the swing improvement device at a portable position;

[0016] FIG. 7 illustrates an alternate embodiment of the transportation apparatus of one embodiment of the swing improvement device; and

[0017] FIG. 8 illustrates another alternate embodiment of the transportation apparatus.

**DETAILED DESCRIPTION OF THE INVENTION**

[0018] The present invention provides a portable and intuitive golf swing improvement device for indicating the proper shift of a golfer's body weight to the front foot during a technically sound down swing. More specifically, the swing improvement device measures the shift of the golfer's body weight during a golf swing and indicates when such shift is in accordance with a technically sound swing. Additionally, the swing improvement device is self-sufficient and portable such that the device is deployable almost anywhere. The swing improvement device also provides swing analysis in a manner that is immediately understandable to the golfer. One embodiment of the golf swing improvement device constructed in accordance with the various features of the present invention is illustrated generally at 10 in FIG. 1.

[0019] The golf swing improvement device 10 includes a mat 12, a pressure switch 14, and an indicator 16. In the illustrated embodiment, the mat 12 is sufficiently large such that a golfer taking a golfer's stance is able to stand with both

feet on the mat 12, as is illustrated at FIG. 2. A golfer's stance is the stance a golfer takes when initiating the swing of a golf club. The pressure switch 14 is disposed at the mat 12 such that the golfer's front foot 18 is positioned on the pressure switch 14 when the golfer takes a stance on the mat 12. The golfer's front foot 18 is the foot in the direction of a golf swing. More specifically, when the golfer swings right handed, as illustrated at FIG. 2, the front foot 18 is the golfer's left foot, and the back foot 20 is the golfer's right foot. Accordingly, when the golfer swings left handed, the front foot 18 is the golfer's right foot, and the back foot 20 is the golfer's left foot.

[0020] FIG. 3 illustrates an exploded view of one embodiment of the pressure switch 14 in accordance with the various features of the present invention. The pressure switch 14 includes an upper housing member 22, a pair of electrodes 24, a biasing spring 26, a pair of electrical contacts 28, and a lower housing member 30. The pressure switch 14 is capable of an open position and a closed position. When the pressure switch 14 is at the open position, the electrodes 24 and the electrical contacts 28 are not in electrical communication. Conversely, when the pressure switch 14 is at the closed position, each of the electrodes 24 is in electrical communication with a respective one of the electrical contacts 28. The pressure switch 14 is biased to the open position by way of the biasing spring 26. More specifically, in the illustrated embodiment, the electrodes 24 are mechanically secured to the under side of the upper housing member 22 such that the electrodes 24 extend from the upper housing member 22 in the direction of the lower housing member 30. Accordingly, the electrical contacts 28 are mechanically secured to the upper side of the lower housing member 30 such that each electrical contact 28 is spatially aligned with a respective electrode 24. The biasing spring 26 mechanically engages the upper housing member 22 and the lower housing member 30 such that the biasing spring 26 biases the pressure switch 14 to the open position. When the swing improvement device 10 is deployed, as illustrated at FIGS. 1 and 2, the lower housing member 30 is positioned against the ground, either directly or by way of the mat 12. As a result, to move the pressure switch 14 to the closed position, a force must be applied to the upper housing member 22, whereby the force is sufficient to overcome the biasing force generated by the biasing spring 26. The biasing force generated by the biasing spring 26 is defined subsequently.

[0021] In the illustrated embodiment, the biasing spring 26 is a wave spring. A wave spring permits the pressure switch 14 to have a low profile such that the pressure switch 14, despite being positioned under the golfer's front foot 18, does not affect the golfer's swing. Additionally, a wave spring provides a more consistent and reliable biasing force against forces that are not parallel with the longitudinal axis of the biasing spring 26. For example, when the golfer swings a club, the front foot 18 shifts laterally such that forces unparallel with the longitudinal axis of the biasing spring 26 are applied against the biasing spring 26. However, it should be noted that the biasing spring 26 can be a spring other than a wave spring without departing from the scope or spirit of the present invention.

[0022] Also, in the illustrated embodiment, the upper side of the upper housing member 22 has a dome-type contour such that the pressure switch 14 does not restrict the movement of the golfer's front foot 18 during the course of a swing. Instead, the contour of the upper housing member 22 permits the golfer's front foot 18 to pivot in accordance with a tech-

nically sound swing. Additionally, in the illustrated embodiment, the upper housing member 22 includes a shoulder 42 that extends beyond the perimeter of the lower housing member 30 and slopes gradually toward the lower housing member 30. This configuration permits the pressure switch 14 to be moved to the closed position without the housing members 22 and 30 restricting such movement and provides protection against environmental elements to the components of the switch 14. It should be noted that the upper side of the upper housing member 22 can have a contour other than a dome-type contour, such as a flat contour, as illustrated at FIG. 4, without departing from the scope or spirit of the present invention. It should also be noted that the upper housing member 22 does not require the shoulder 42 to remain within the scope or spirit of the present invention.

[0023] FIG. 5 is a block diagram of one embodiment of the swing improvement device 10 in accordance with the various features of the present invention. The swing improvement device 10 includes a power source 32, the pressure switch 14, and the indicator 16. The power source 32 is in electrical communication with the pressure switch 14, which is in electrical communication with the indicator 16. Stated differently, the power source 32 is in electrical communication with the indicator 16 by way of the pressure switch 14. When the pressure switch 14 is at the open position, the power source 32 is not in electrical communication with the indicator 16 such that the indicator 16 is not provided with operating power. Conversely, when the pressure switch 14 is at the closed position, the circuit is complete such that the power source 32 is in electrical communication with the indicator 16. When in electrical communication with the indicator 16, the power source 32 provides the indicator 16 with operating power such that the indicator 16 is activated. As a result, when a force sufficient to overcome the biasing force is applied to the upper housing member 22 of the pressure switch 14, the indicator 16 is activated.

[0024] When activated, the indicator 16 generates an indication that is perceivable by the golfer. For example, in one embodiment the indicator 16 generates an audible indication, such as a tone. When the indicator 16 generates an audible indication, the indicator 16 can be, for example, a piezoelectric buzzer. In one embodiment, the indicator 16 generates a visible indication, such as a flashing light. When the indicator 16 generates a visible indication, the indicator 16 can be, for example, an LED. The indicator 16 is disposed at the mat 12 such that the indication is perceivable by the golfer or at least another, such as an instructor.

[0025] Considering the above discussion in conjunction with FIG. 2, when the golfer takes a golfer's stance on the mat 12, the golfer's front foot 18 is positioned on the upper housing member 22 of the pressure switch 14. Prior to initiating the golf swing, the golfer's body weight is substantially evenly distributed between the front foot 18 and the back foot 20. The biasing force of the biasing spring 26 is such that the force applied to the upper housing member 22 by the front foot 18 when the golfer is at this initial position is not sufficient to overcome the biasing force. As a result, when the golfer is at this initial position, the indicator 16 is not activated. When the golfer initiates the swing, the golfer first takes a back swing. As the golfer takes the back swing, the body weight of the golfer is shifted such that a majority of the golfer's body weight is at the back foot 20. As a result, when the golfer is at the top of the back swing, the indicator 16 is not activated. When the golfer performs a technically sound down

swing and corresponding follow-through, the majority of the golfer's body weight shifts from the back foot **20** to the front foot **18**. When this majority of body weight is shifted to the front foot **18**, the body weight then supported by the front foot **18** generates a force against the upper housing member **22** of the pressure switch **14** that is sufficient to overcome the biasing force generated by the biasing spring **26**. As discussed above, when the biasing force is overcome, the indicator **16** is activated such that it generates the indication. As a result, when the golfer's body weight shifts in accordance with a technically sound golf swing, the indicator **16** generates the indication. Stated differently, when the golfer performs a technically sound golf swing, the indicator **16** indicates such.

[0026] Because the body weight of one golfer can differ significantly from another, in one embodiment of the pressure switch **14**, the biasing force generated by the biasing spring **26** is adjustable. More specifically, in one embodiment, the extent to which the electrodes **24** extend from the under side of the upper housing member **22** is adjustable. The more the electrodes **24** extend from the upper housing member **22**, the less distance there is between the electrodes **24** and the electrical contacts **28** when no external force is applied against the upper housing member **22**. As a result, the force required to overcome the biasing force, that is, the force required to move the electrodes **24** into electrical communication with the electrical contacts **28**, is reduced. As a result, adjusting the position of the electrodes **24** enables the pressure switch **14** to be adjusted to accommodate golfers of various body weights. In one embodiment, the electrodes **24** are secured to the upper housing member **22** by way of cooperating threaded portions such that as each of the electrodes **24** is rotated about its longitudinal axis, the extent to which the electrode **24** extends from the upper housing member **22** is adjusted. It should be noted that the extent to which the electrodes **24** extend from the under side of the upper housing member **22** can be adjustable by ways other than the electrodes **24** having cooperating threaded portions without departing from the scope or spirit of the present invention.

[0027] In another embodiment, the pressure switch **14** is adapted such that the biasing spring **26** is readily replaceable. In this embodiment, multiple biasing springs **26** of various tensions are selectively used with the pressure switch **14** such that the tension of the currently employed biasing spring **26** governs the biasing force. As a result, the force required to move the pressure switch **14** to the closed position is adjustable in that it is based on the currently employed biasing spring **26**. Stated differently, replacing the biasing spring **26** adjusts the required force exerted by the golfer to move the pressure switch **14** to the closed position such that the pressure switch **14** can be adjusted to accommodate golfers of various body weights. In the illustrated embodiment, when one of the bolts **46** is removed, the spatial relationship between the upper housing member **22** and the lower housing member **30** is such that the biasing spring **26** can be removed from and inserted within the pressure switch **14**. Although, two specific embodiments of an adjustable pressure switch **14** have been discussed above, it should be noted that the biasing force generated by the biasing spring **26** can be adjustable by ways other than those discussed above without departing from the scope or spirit of the present invention.

[0028] In the illustrated embodiments of FIGS. 3 and 4, the upper housing member **22** defines at least one opening **44** adapted to receive a bolt **46** having a male threaded member. Additionally, the lower housing member **30** defines at least

one nut-type structure **48** having a female threaded member adapted to cooperate with the threaded member of the bolt **46** such that the bolt **46** can be secured to the nut-type structure **48** in accordance with a conventional bolt-nut configuration. When received by the first opening **44**, the bolt **46** extends therethrough and engages with the nut-type structure **48** in accordance with the above discussion. As a result, when the bolt **46** engages the nut-type structure **48**, the bolt **46** can be tightened with respect to the nut-type structure **48** such that the bolt **46** and nut-type structure **48** overcome the biasing force and move the upper housing member **22** closer to the lower housing member **30**, partially compressing the biasing spring **26**. In doing this, the overall height of the pressure switch **14** is adjusted to accommodate, for example, the preference of the golfer or the mechanics of a given exercise.

[0029] Considering the above discussion, the golf swing improvement device **10** indicates a technically sound golf swing in a manner that is immediately and unambiguously recognizable to the golfer or another. Additionally, no component of the swing improvement device **10** is attached or tethered to the golfer such that the golfer is able to take a golf swing using the device **10** and then immediately step away from the device **10** and take a swing without using the device **10**. This assists the golfer is developing lower body muscle memory.

[0030] In the illustrated embodiment, the golf swing improvement device **10** provides a portability feature. More specifically, in the illustrated embodiment, the mat **12** is capable of being manipulated to a portable position, and the swing improvement device **10** includes a mat securing apparatus **34** and a transportation apparatus **36**. In the illustrated embodiment, the mat securing apparatus **34** includes a plurality of securing straps secured to a first side **38** of the mat **12**. Each securing strap **34** is adapted to be removably secured to at least a portion of the under side of the mat **12**. For example, on one embodiment, the securing strap **34** is removably secured to the under side of the mat **12** by way of a hook-and-loop fastener configuration. In the illustrated embodiment, the mat **12** is manipulated to the portable position by rolling the mat **12** from a second end **40**, which is opposite the first end **38**, to the first end **38**. When the mat **12** is fully rolled, each securing strap **34** is wrapped about at least a portion of the rolled mat **12** and fastened to the under side of the mat **12**, for example, using the integral hook-and-loop fastener, securing the mat **12** at the rolled, or portable, position, as illustrated at FIG. 6. When the device **10** is secured at the portable position, the device **10** can be carried using the transportation apparatus **36**, which, in the illustrated embodiment, is a strap secured to the mat **12**. It should be noted that the device **10** can be manually carried using the transportation apparatus **36**, such as over the shoulder of the golfer, or can be attached to, for example, a golf bag. It should also be noted that the mat securing apparatus **34** and the transportation apparatus **36** can be apparatus other than those illustrated without departing from the scope or spirit of the present invention.

[0031] FIG. 7 illustrates an alternate embodiment of the transportation apparatus **36** in accordance with the various features of the present invention. In the alternate embodiment, the transportation apparatus **36** is removably secured to the mat **12**. In the illustrated embodiment, the transportation apparatus **36** is secured to the mat **12** by way of a loop structure **44**, the loop structure **44** being secured to the mat **14** and adapted to receive the transportation apparatus **36**. When received by the loop structure **44**, the transportation apparatus

36 is removably secured to itself, defining a loop about the loop structure 44 and removably securing the transportation apparatus 36 to the mat 12. In the illustrated embodiment, the transportation apparatus 36 is removably secured to itself using a hook-and-loop fastener configuration. However, it should be noted that the transportation apparatus 36 can be removably secured to itself by ways other than a hook-and-loop fastener without departing from the scope or spirit of the present invention.

[0032] FIG. 8 illustrates another alternate embodiment of the transportation apparatus 36 in accordance with the various features of the present invention. In this alternate embodiment, the transportation apparatus 36 includes a first transportation apparatus member 36a and a second transportation apparatus member 36b. The first transportation apparatus member 36a is removably secured to the second transportation apparatus member 36b. In the illustrated embodiment, this is accomplished using a hook-and-loop fastener configuration. However, it should be noted that the first transportation member 36a can be removably secured to the second transportation apparatus member 36b by ways other than a hook-and-loop fastener without departing from the scope or spirit of the present invention. The alternate embodiments of FIGS. 7 and 8 facilitate the swing improvement device 10 being secured to certain objects, such as a golf bag.

[0033] From the foregoing description, those skilled in the art will recognize that a golf swing improvement device for indicating the proper shift of a golfer's body weight to the front foot during a down swing offering advantages over the prior art has been provided. More specifically, the swing improvement device measures the shift of the golfer's body weight during a golf swing and indicates when such shift is in accordance with a technically sound swing. Additionally, the swing improvement device is self-sufficient and portable such that the device is deployable almost anywhere. The swing improvement device also provides swing analysis in a manner that is immediately understandable to the golfer.

[0034] While the present invention has been illustrated by description of several embodiments and while the illustrative embodiments have been described in considerable detail, it is not the intention of the applicant to restrict or in any way limit the scope of the appended claims to such detail. Additional advantages and modifications will readily appear to those skilled in the art. The invention in its broader aspects is therefore not limited to the specific details, representative apparatus and methods, and illustrative examples shown and described. Accordingly, departures may be made from such details without departing from the spirit or scope of applicant's general inventive concept.

Having thus described the aforementioned invention, what is claimed is:

1. A golf swing improvement device for indicating the proper shift of a golfer's body weight during a golf swing, said golf swing improvement device comprising:

a mat sufficiently large such that the golfer is able to take a golfer's stance on said mat such that at least the golfer's front foot is positioned on said mat;

a pressure switch disposed at said mat such that the front foot is positioned on said pressure switch when the golfer takes the golfer's stance on said mat, said pressure switch being movable between an open position and a closed position, said pressure switch being biased to the open position by a biasing force, said pressure switch being moved to the closed position when a force suffi-

cient to overcome the biasing force is applied to the pressure switch, the force of the front foot against said pressure switch is sufficient to overcome the biasing force when the golfer shifts its body weight to the front foot in accordance with a technically sound down swing; and

an indicator in electrical communication with said pressure switch, said indicator generates an indication when said pressure switch is at the closed position.

2. The golf swing improvement device of claim 1 wherein said pressure switch includes a spring, said spring biases said pressure switch to the open position.

3. The golf swing improvement device of claim 2 wherein said spring is a wave spring.

4. The golf swing improvement device of claim 1 wherein the force sufficient to overcome the biasing force is adjustable.

5. The golf swing improvement device of claim 1 wherein the height of the pressure switch is adjustable.

6. The golf swing improvement device of claim 1 wherein the indication generated by said indicator includes an audible indication.

7. The golf swing improvement device of claim 6 wherein said indicator is a piezoelectric buzzer.

8. The golf swing improvement device of claim 1 wherein the indication generated by said indicator includes a visual indication.

9. The golf swing improvement device of claim 1 wherein said mat is capable of a portable position, said mat being increasingly portable when at the portable position.

10. The golf swing improvement device of claim 9 further comprising a mat securing apparatus, said mat securing apparatus being adapted to maintain said mat at the portable position.

11. The golf swing improvement device of claim 10 wherein said mat securing apparatus maintains said mat at the portable position using a hook-and-loop fastener.

12. The golf swing improvement device of claim 9 further comprising a transportation apparatus secured to said mat such that said golf swing improvement device is adapted to be carried by way of said transportation apparatus.

13. The golf swing improvement device of claim 12 wherein said transportation apparatus includes a first transportation apparatus member and a second transportation apparatus member, each of the first transportation apparatus member and the second transportation apparatus member being secured to said mat, the first transportation apparatus member being removably secured to the second transportation apparatus member.

14. The golf swing improvement device of claim 13 wherein the first transportation apparatus member is removably secured to the second transportation apparatus member by way of a hook-and-loop fastener.

15. The golf swing improvement device of claim 12 wherein said transportation apparatus is removably secured to said mat.

16. The golf swing improvement device of claim 15 wherein said transportation apparatus is removably secured to said mat by way of a hook-and-loop fastener.

17. A golf swing improvement device for indicating the proper shift of a golfer's body weight during a golf swing, said golf swing improvement device comprising:

a mat sufficiently large such that the golfer is able to take a golfer's stance on said mat such that at least the golfer's

front foot is positioned on said mat, said mat being movable to a portable position;

a pressure switch disposed at said mat such that the front foot is positioned on said pressure switch when the golfer takes the golfer's stance on said mat, said pressure switch being movable between an open position and a closed position, said pressure switch including a mechanical spring that biases said pressure switch to the open position, said pressure switch being moved to the closed position when a force sufficient to overcome the spring bias is applied to the pressure switch, the force of the front foot against said pressure switch being sufficient to overcome the spring bias when the golfer shifts its body weight to the front foot in accordance with a technically sound down swing;

an indicator in electrical communication with said pressure switch, said indicator generates an indication when said pressure switch is moved to the closed position;

a mat securing apparatus adapted to maintain said mat at the portable position; and

a transportation apparatus secured to said mat, said golf swing improvement device being adapted to be carried by way of said transportation apparatus.

**18.** The golf swing improvement device of claim 17 wherein the spring of said pressure switch is a wave spring.

**19.** The golf swing improvement device of claim 17 wherein the force sufficient to overcome the spring bias is adjustable.

**20.** The golf swing improvement device of claim 19 wherein said pressure switch includes an upper housing

member, a lower housing member, a plurality of electrodes, and a plurality of electrical contacts, the plurality of electrodes being secured to the upper housing member, the plurality of electrical contacts being secured to the lower housing member, said pressure switch being at the closed position when at least one of the plurality of electrodes is in electrical communication with at least one of the plurality of electrical contacts, the extent to which the electrodes extend from the under side of the upper housing member being adjustable.

**21.** The golf swing improvement device of claim 19 wherein said pressure switch is adapted such that the mechanical spring is readily replaceable.

**22.** The golf swing improvement device of claim 21 wherein said pressure switch includes a plurality of mechanical springs, each of the plurality of mechanical springs having a different tension, the force sufficient to overcome the spring bias being governed by which of the plurality of mechanical springs is employed.

**23.** The golf swing improvement device of claim 17 wherein said transportation apparatus is removably secured to said mat.

**24.** The golf swing improvement device of claim 17 wherein said transportation apparatus includes a first transportation apparatus member and a second transportation apparatus member, each of the first transportation apparatus member and the second transportation apparatus member being secured to said mat, the first transportation apparatus member being removably secured to the second transportation apparatus member.

\* \* \* \* \*